

DSP-powered Voice Alarm System

GRÄF & MEYER

System family EVA 16 M/S

**EVA 16 M
EVA 16 S
EVA Line**

Manual english

**Rev. 4.33d -E- 121214
Dec. 2012**



1438

**GRÄF & MEYER GmbH, Ringstraße 1, D-66459 Kirkel-Limbach
12
1438/CPD/0235**

EN 54-16

**Sprachalarmzentrale für Brandmeldeanlagen für Gebäude
EVA System**

Vorgesehene Optionen :

Stufenweise Räumung

Manuelles Abstellen des Sprachalarmzustands

Manuelles Rückstellen des Sprachalarmzustands

Anzeige von Störungen im Übertragungsweg zur BMZ

Anzeige von Störungen in Lautsprechergruppen

Manuelles Auslösen der Sprachalarmierung

Notfallmikrofon

Redundante Leistungsverstärker

Technische Daten: Siehe Anhang am Ende dieses Manuals

Contents

0.	Document of certification.....	2
1.	Introduction: System Family.....	5
1.1	Common description EVA 16 M/S / EVALINE.....	5
1.1.1	Main Features EVA 16 M/S.....	6
1.1.2	Main Features EVA LINE.....	7
2.	Description.....	8
2.1	Features EVA 16 M/S:.....	8
2.1.1	Frontview EVA 16 M/S (identical for master- and slave- version).....	8
2.1.2	Frontview EVALINE.....	10
2.1.3	PowerUp / Language Selection / Factory Reset.....	12
2.1.4	Adjusting the Level of an Available Input Source :.....	13
2.1.5	Rearview EVA 16 M/S (identically for master- and slave- version).....	14
2.1.6	Rearview EVA LINE.....	18
2.2	Smallest possible system configuration.....	20
2.3	The MP3-Memory Card (EVA 16 M respective EVA 16 S only).....	21
2.4	Priority – Administration (EVA 16 M respective EVA 16 S only).....	22
3.	External components :.....	23
3.1	Standard – microphone-desks : (EVA 16 M respective EVA 16 S only).....	23
3.1.1	EVA 16 SYS 80 (EVA 16 M respective EVA 16 S only).....	24
3.1.2	EVA 16 TER (EVA 16 M respective EVA 16 S only).....	26
3.1.3	EVA 16 SYS 4W (EVA 16 M respective EVA 16 S only).....	30
3.1.4	EVA 16 SYS 2 - EVA 16 SYS 4+1 (EVA 16 M respective EVA 16 S only)...	31
3.2	Fire - Mics :.....	32
3.2.1	EVA 16 SYS FT (EVA 16 M respective EVA 16 S only).....	32
3.2.2	EVA 16 SYS FH (EVA 16 M respective EVA 16 S only).....	33
3.2.3	EVA 16 FIRE PANEL.....	34
3.3	I/O-Port (extern).....	37
3.4	Connecting the Alarmcontacts.....	39
3.5	external relay board EVA 16 REL.....	41
3.5.1	Common description: Relayboard EVA REL.....	42
3.5.2	Description :.....	42
3.5.3	Decoder „Bus-Function“.....	44
3.5.4	Decoder „Global-Function“.....	45
3.5.5	Decoder „Contact-Function“.....	45
3.5.6	Four relay blocks :.....	46
3.5.7	Powersupply for relay blocks.....	46

3.5.8	<i>Connecting Data Bus</i>	46
3.5.3	<i>Technical Data</i> :	47
4.0	<i>Operation</i>	49
4.1	<i>Start-up</i> :.....	49
4.1.0	<i>PowerUp / Language Selection / Factory Reset</i>	49
4.1.1	<i>Start of the installation-run</i>	50
4.1.2	<i>displaying the identified components</i>	51
4.2	<i>Music: Level and Routing of enabled sources</i>	55
4.3	<i>Error – messages at the System EVA16</i> :	56
5.	<i>Programming</i>	62
5.1	<i>Level and routing / disabling and enabling of audio-sources</i> :	62
5.2	<i>relay programming</i> :.....	64
5.3	<i>Special functions:</i>	64
5.4	<i>ALARM-START</i>	65
5.5	<i>ALARM-CODE-Page (additional only on slave-units !)</i>	66
5.6	<i>impedance tolerance</i> :	66
5.7	<i>Level of pilot signal</i> :	67
5.8	<i>Measurement (MESSUNG)</i> :	67
5.9	<i>POWER – ON – RESET</i> :	68
6.	<i>Connecting a PC</i>	69
6.1	<i>Using WINDOWS XP © Hyperterminal</i>	69
6.2	<i>Download and Upload of parameters using EVAMON</i>	75
7.	<i>Appendix</i> :.....	76
7.1	<i>System setups (examples)</i>	76
7.2	<i>Planning a system / Help</i>	80
7.3	<i>Tips for planning and installation</i> :	84
7.4	<i>Technical Data</i>	85

1. INTRODUCTION: SYSTEM FAMILY

EVA 16 M/S, **EVA16 S** and **EVALINE** are part of a complete range of products to set up Public Address and Voice Alarm Systems compliant with the actual standards and regulations DIN/EN 60849 respective DIN EN 54-16

In this product range you will find central controllers like **EVA 16**, the amplifier and zone extension module **EVALINE**, the emergency power supply unit **EVA 24/54**, the amplifiers of the **SINUS**-series or the firemen microphone- terminals **EVA 16 SYS FT**, **EVA 16 SYS FH** and **EVA 16 FirePanel**.

1.1 COMMON DESCRIPTION EVA 16 M/S / EVALINE

The system EVA 16 originally was developed to set up public address and Voice Alarm System to be in accordance with DIN/EN60849 (VDE 0828).

The central unit **EVA 16 M/S** manages the distribution of live spoken announcements, memorized emergency and evacuation calls, chimes or background music; it organizes all requested supervision functions; the effects of detected problems will be minimized.

In minimum setup the system works with one standard amplifier and one spare amp; there can be handled up to eight complete speaker lines, wired as 8 complete A/B- zones.

In case of more zones required, up to 9 more units **EVA 16 S** resp. **EVA Line** can be tied together to a centralized or decentralized system.

Announcements or signal tones are stored in MP3-format on a SD memory card. The functionality of the audio memory is permanently supervised. Content may be changed by a trained installation company (CAUTION: the memory card is located inside the unit; the central unit has to be opened).

In order to submit the connection of all components and all functions in an electro installation box, there is an optional external I/O-Board, connected via Standard Dsub-25pin-cable to the central unit **EVA 16 M/S**. In addition, there were dry relay contacts like "general fault" and "obligation-call".

EVALINE permanently monitors connected amplifiers and speakerlines. In association with **EVA 16** systems you can extend the number of monitored speaker lines. Prerecorded announcements may be triggered or live announcements may be performed form terminals **EVA 16 TER**, **EVA 16 SYS 80** or **EVA 16 FirePanel** in combination with optional temporary zone mute by relays.

EVA 16 M/S respective **EVALINE** identify all the connected components by an automatic Installation run. All the component-names were shown in the display. After the end of the installation run, the system checks permanently the proper function of all identified components.

Any fault generates a corresponding system reaction and/or a notice.

The use of actual DSP-technologies allows future upgrades.

Possible applications were found at schools, shops, factories, administration buildings and hotels.

1.1.1 MAIN FEATURES EVA 16 M/S

- Supervision of up to eight (8) power-amps (100V), connected via four (4) transformer-balanced outputs with separate volume and tone control (treble and bass).
- Supervision of a 100V-spare-amp: connected via transformer-balanced output.
- Supervision of up to 8 speaker-zones, consequently wired as A/B-lines, so there are 16 measurement-zones. Supervision of every connected zone to broken line, impedance change, short line and ground fault. A detected short-line causes the separation of the corresponding speaker line.
- Connection-point for two (2) fire-mics on the rear of the central unit, but also one (1) on the front panel (handheld mic). Coils and request-lines were supervised to broken line and short line
- Connection-points for up to eight (8) supervised system-mics:
EVA16 TER (supervised) with special function buttons
EVA 16 SYS 80 (supervised) and/or
EVA 16 SYS 4, EVA 16 SYS 2, (not supervised, as many as desired)
- Up to 80 call-zones; programmable pre-announcement chime.
Optional switching ON/OFF the complete music section by EVA16 SYS 80 or EVA16 TER (depending on configuration.)
- Two (2) contact inputs to activate the AUX-Audio-inputs (for commercials f.e.); free routing and level configuration for each audio output.
- Four (4) music inputs with full audio matrix-function; free routing and level configuration for each audio output.
- Four (4) prerecorded alarm-messages (evacuation message f.e.) selectable triggering by external supervised contact closure; full audio matrix-function with free routing and level configuration for each audio output; additional covered start-button for ALARM1 at the frontpanel of the system. Two (2) stored text-messages ("closing the shop"/ "end of opening time" f.e.) selectable triggering by external contact closure; full audio matrix-function with free routing and level configuration for each audio output; (for example: timer-controlled...)
- External triggerable chime with full audio matrix-function; free routing and level configuration for each audio output;
- Messages and audio signals stored on SD/MMC-flashcard as MP3-files; internal player permanently supervised.
- Easy system configuration by buttons and LC-display on the front of the unit; PC-interface port provided, PC not required for system-setup, but suggested.
- Fault detection relay for general fault or power failure.
Obligation relay to bypass external speaker-level-control (on optional I/O-Board)
- Automatic program-mute and audio low cut in case of 24V-operation
- Up to 10 units stackable (master/slave - procedure)

1.1.2 MAIN FEATURES EVA LINE

- Two (2) audio inputs/outputs for passing through the audio signal.
- Supervision of up to eight (8) power-amps (100V), connected via two (2) transformer-balanced outputs
- When using in combination with a system EVA 16 M/S , one or two of the EVA 16 audio outputs will be connected to the audio inputs of the EVA Line. Then it can be configured whether these connections are monitored or not. In addition the control bus "CASCADE" has to be connected . (When using together with a GRÄF&MEYER - GREE MATRIX system, the audio connections have to be established in the same way but no control bus connection can be made; the firmware of a GREEMATRIX-BasicUnit has to be a special revision.) At EVALINE it can be configured whether it is connected to an EVA 16 or GREEMATRIX . EVALINE works with any preamplifier; if the preamp does not fit the 22kHz – pilot signal with 100 mVpp level to its audio outputs, it is necessary to switch off the monitoring of this connection.
- supervision of a 100V-spare-amp: connected via transformer -balanced output.
- Supervision of up to 8 speaker-zones, consequently wired as A/B-lines, so there are 16 measurement-zones. Supervision of every connected zone to broken line, impedance change, short line and ground fault. A detected short-line causes the separation of the corresponding speaker line.
- Up to 80 call-zones when using EVA 16 M and EVA16 SYS 80 or EVA16 TER (depending on configuration.)
- Easy system configuration by buttons and LC-display on the front of the unit; PC-interface port provided, PC not required for system-setup, but suggested
- Fault detection relay for general fault or power failure.

2. DESCRIPTION

2.1 FEATURES EVA 16 M/S:

2.1.1 FRONTVIEW EVA 16 M/S (IDENTICAL FOR MASTER- AND SLAVE- VERSION)

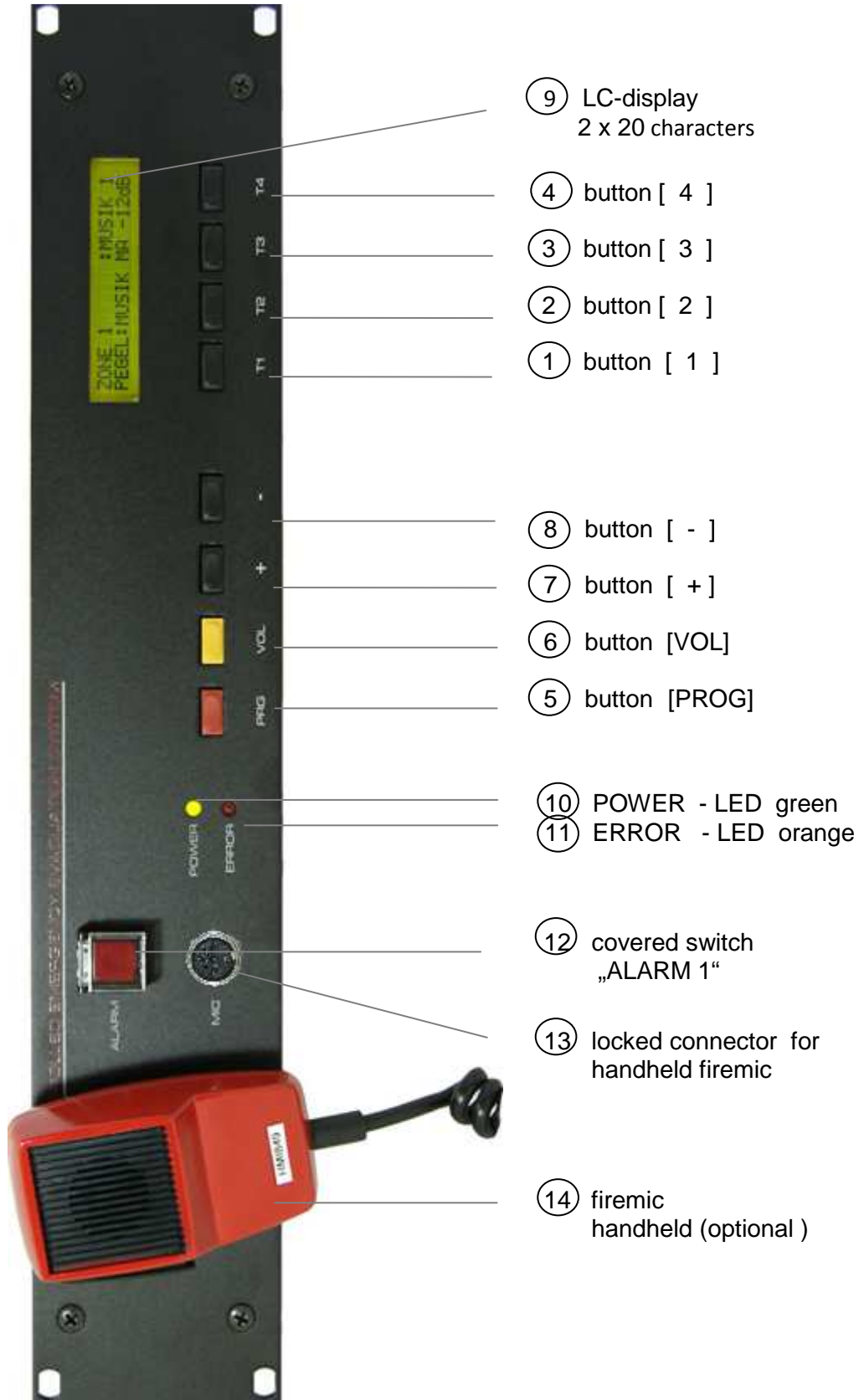

- 1: button [T1]
- 2: button [T2]
- 3: button [T3]
- 4: button [T4]
- 5: PROGRAMM- button [**PRG**]
- 6 VOLUME- button [**VOL**]
- 7: + button [+] increase
- 8: - button [-] decrease
- 9: LC-display , 2 x 20 character
- 10: POWER - LED
Indicates the presence of the 230V – line voltage
- 11: ERROR – LED
Indicates an actual fault;
on system POWER-ON: some seconds blinking for system check
- 12: ALARM 1 (covered switch)
- 13: lockable connector for handheld firemic
Only one firemic at a time allowed for the connector on the front panel, the firemic1 connectors on the back panel or the firemic1 port on the I/O extension card (including EVA 16 FP FirePanel)
- 14: handheld firemic

2.1.2 FRONTVIEW EVALINE

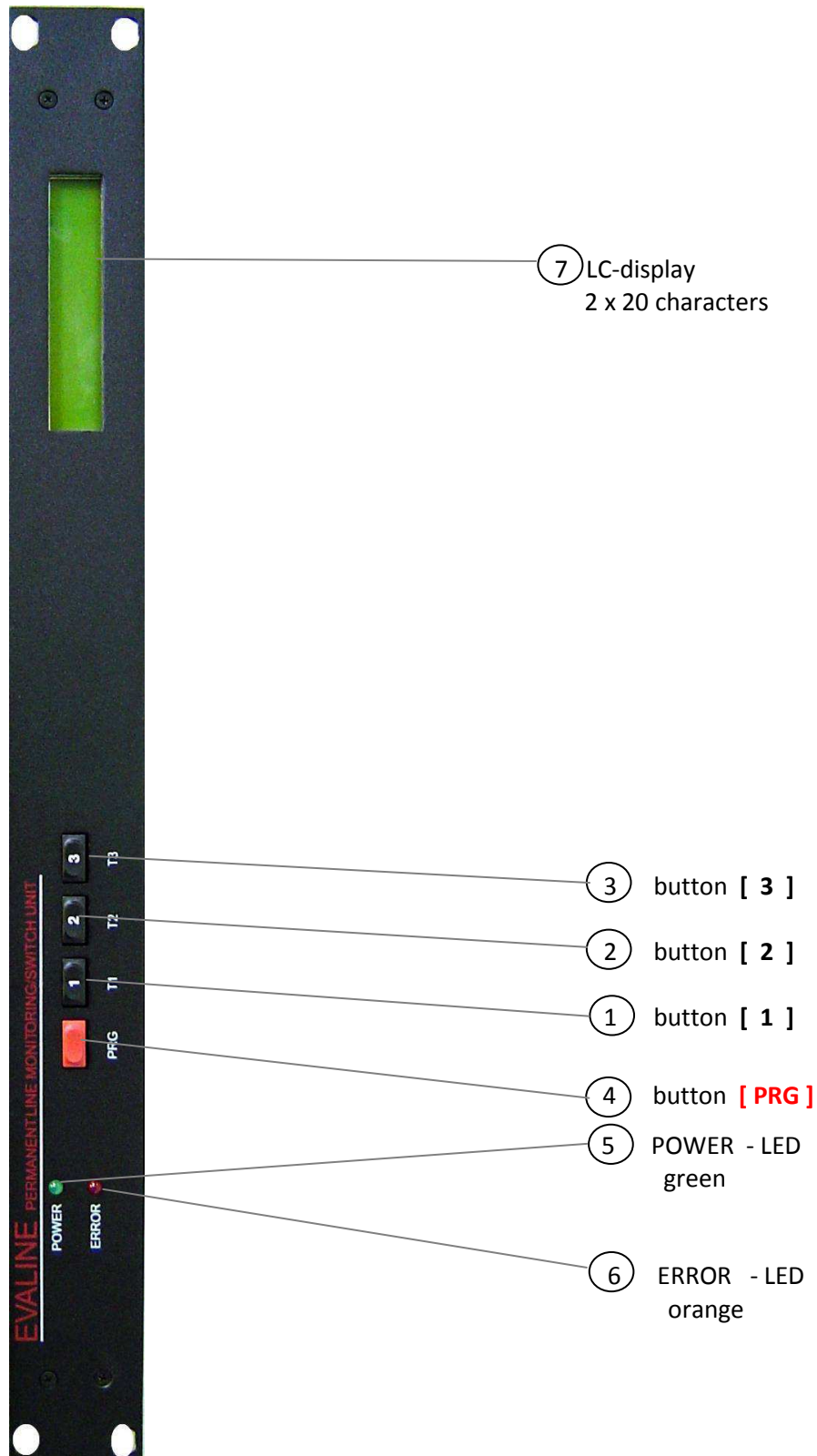

- 1: button [T1]
- 2: button [T2]
- 3: button [T3]
- 4: PROGRAMMING – button [PRG]
- 5: POWER – LED, green
Indicating the presence of 230V – mains supply
- 6: ERROR – LED, orange
Indicating an actual present error;
on POWER UP LED is blinking for a short time.
- 7: LC-Display , 2 x 20 characters

2.1.3 POWERUP / LANGUAGE SELECTION / FACTORY RESET

After connecting to the power / turning on the unit, system comes up as follows

```
language      V n.n
```

language stands for the selected language of the user interface / menus

V n.n is the installed firmware
... and 2 seconds later

```
V n.n      dd.mm.yy
```

dd.mm.yy : date of release of the installed firmware

... and within another 2 seconds :
for EVA 16

```
ZONE 1:      MUSIC 1  
SYSTEM_OK    EVA16M
```

resp. for EVA Line

```
                EVALINE  
SYSTEM: OK
```

normal view

Language :

Selection of the language by pushing and holding one of the buttons on front plate during powerup :

- [T1] for GERMAN
- [T2] for ENGLISH resp..
- [T3] for FRENCH.

The system automatically saves the selected language for next system start – even through a FACTORY – RESET !

Factory default is GERMAN

Similar for microphone terminal EVA 16 TER and EVA 16 SYS 80

Factory Reset :

Resetting the units parameters to the factory default settings occurs by pushing and holding the buttons [PRG] und [T3] during powerup

Only the language selection will not be affected from this factory reset.

2.1.4 ADJUSTING THE LEVEL OF AN AVAILABLE INPUT SOURCE :

Adjusting a level :

ZONE 1	MUSIC 1
SYSTEM_OK	EVA16M

Starting with this standard display view :

The zone to be edited will be selected by pressing one of the buttons [T1] ... [T4]. The zone names may be configured. (ref 6.1)

Selecting the active source :

Every further pressing of the same button leads on to the next available (not blocked) source to be routed to the actual output zone.

One or more music sources may be blocked.

Example.: *music 1 / music 4* /=> and back again to music 1; the two other inputs are blocked and may not be selected for the playout to the actual output zone.

Selecting the source to be edited :

By the first pressing of the button [VOL] the display shows the level-menue:

ZONE 1	MUSIC 1
LEVEL: MUSIC 3	-12dB

ATTENTION: the source to be edited not mandatory is the source displayed in the upper line of the display !!!

Selecting the source which level has to be edited for the actual displayed output zone by pressing one or more times the button [VOL] .

The sources will appear in the lower display line in the following order :

MUSIC 1 => MUSIC 2 => MUSIC 3 => MUSIC 4 => MUSIC MASTER => chime => TEXT 1 => TEXT 2 => AUX 1 => AUX 2 => and music 1 again ...

setting the volume :

pressing the buttons [+] respective [-] changes the audio level for the displayed crosspoint of input source and output zone.

+ : raises - : reduces the level

Valid values for the levels are

- For music 1..4, chime, text 1..2, AUX 1..2 : “ -16dB” ... “ -00dB”
- For music master “ -30dB” ... “ -00dB”

If " - - dB" appears behind a selected input, so this input may not be activated for the actual displayed output; this connection is blocked by programming, the source can not be routed to the actual displayed output zone.

(also ref. installation run)

(return to standard display view by pressing [PRG] two times - or by waiting a few seconds, then the system returns automatically to the standard view.)

2.1.5 REARVIEW EVA 16 M/S (IDENTICALLY FOR MASTER- AND SLAVE- VERSION)

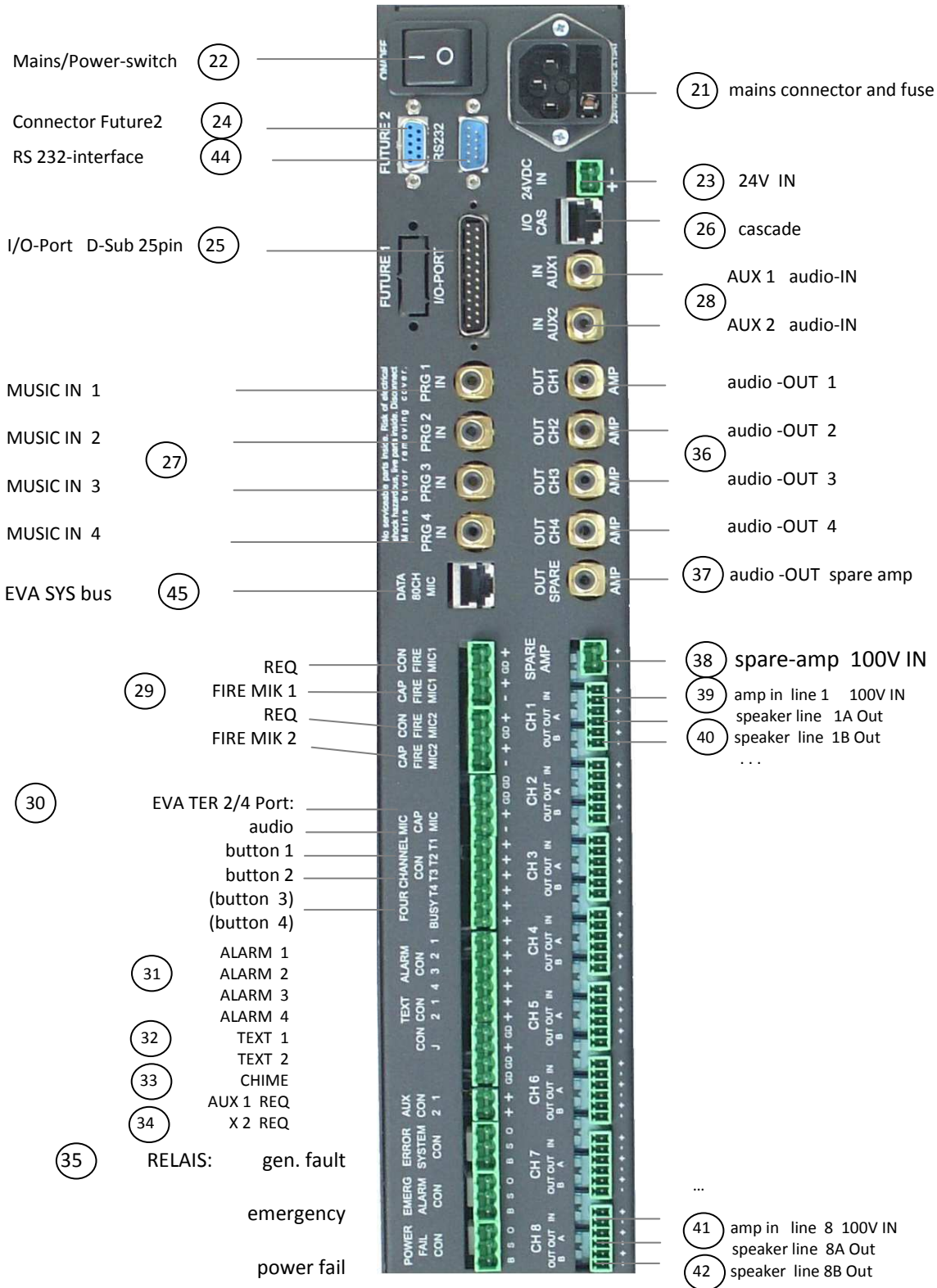

Pinout "Future2" :

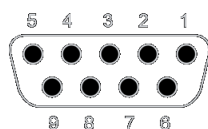

1. programming-mode
2. nc.
3. external mains failiure -
4. external mains failiure -
5. battery error
6. programming-mode
7. nc..
8. nc.
9. battery error

- 21: power connector
230V / 50 Hz euro-connector with integrated fuse ;
fuse 5x20mm 3,15A slowblow.
(with equipped battery – emergency power :) missing main power causes a failure message, muting of program inputs *music 1 ...4* and activates a low cut for all audio outputs to save battery power.
- 22: Mains switch ON / OFF
Separates the central unit from mains power.
ATTENTION: the switch does not affect the 24V-power supply.
- 23: 24V connector:
2pin plug (included) to connect the emergency battery.
(when main power is present :) missing battery voltage causes a failure message
- 24: RS232 interface D-Sub 9pol(m)
connection to the PC by cross-cable [2-3 / 3-2 / 5-5]
Using a suitable communication program (f.e. WINDOWS © XP hyperterminal) much useful parameters can be viewed and set, saved in a protocol-file ; even the zone-identification for the naming of the output-lines can be set here
- 25: I/O-Port D-Sub 25pol (m)
Connection to an (optional) external I/O-Board; D-Sub25pin cable
(cable included with the I/O – Port)
- 26: Cascade-connector RJ45: (I/O CAS)
Optional connection to one or more salve-units EVA 16 S and/or EVALine
The connection uses all 8 pins of the connector. It's not a LAN – connection.
Additional slaves EVA 16 S have to be connected in parallel - using an appropriate connector (included with EVA 16 S slave on request)
- 27: Music 1 In / Music 2 In / Music 3 In / Music 4 In
4 Cinch-connectors for background-music.
- 28: AUX 1 program In / AUX 2 program In
Two (2) phoenix-plugs to connect line-level audio signals f.e. for commercial spots or other sound sources. Sending the sound to speaker line unconditionally needs an active request on the corresponding request pin.
- 29: FireMic1 - In / FireMic2 – In (audio and request).
Two (2) phoenix-plugs to connect dynamic capsules of fire-mics Two (2) phoenix-plugs to connect the corresponding request lines.
Capsule and request lines supervised on short line, broken line and ground fault.
Sending the sound to a speaker line unconditionally needs an active request on the corresponding request pin (PTT).
Only one firemic at a time allowed for the connector on the front panel, the firemic1 connectors on the back panel or the firemic1 port on the I/O extension card (including EVA 16 FP FirePanel).

- 30: EVA-SYS 2/4 Port
 phoenix-plug to connect dynamic capsules of EVA SYS 2 or EVA SYS 4
 phoenix-plugs to connect corresponding line-buttons of EVA SYS x
 the port is not supervised.
 Sending the sound to a speaker line unconditionally needs an active request on the corresponding line-button.
- 31: 4x alarm-input: ALARM 1 .. ALARM 4
 phoenix-plug to connect 4 external alarm-lines
 the request lines are supervised. Please refer to the prescribed interior wiring of the alarm boxes (following later in this manual).
- 32: text 1-start / text 2 -start
 Phoenix-plug to connect the request-signal for starting the replay of two internal stored audio-signals; (“we close the shop ... “ or similar)
 while playing the spot, the signal feeds the programmed zone(s) with programmed volume.
- 33: Chime trigger
 Phoenix-plug to connect the request-signal for triggering the replay of an internal stored audio-signal, this may be a chime (default) ;
 while reproducing the file, the signal feeds the programmed zone(s) with programmed volume.
- 34: AUX 1 – request / AUX 2 – request
 Phoenix-plug to connect the request-signal for enabling the corresponding audio-signal on inputs AUX 1 program In / AUX 2 program In.)
- 35: Indication relays: general fault / emergency / power fail
 On the back panel of the central units EVA 16 M/S fault messages are available as follows :
 general fault / system error : fault message combining all the fault messages of the system to a common message
 emergency: the signal indicates a running alarm started by a alarm box or a micro
 power fail : indicates the absence of one of the energy-sources mains or battery
- 36: Audio Out 1 / Audio Out 2 / Audio Out 3 / Audio Out 4
 Four (4) transformer balanced audio line-outputs to feed the 100V-amplifiers for the speaker zones.

- 37: Spare amp out
Transformer balanced, free of ground audio line-output to feed the 100V-spare amplifier of the system. The presence of a spare amp on each EVA 16 M/S is mandatory to fulfill the regulations of EN 60849.
- 38: 100V In from spare amp
100V-input to connect the 100V-signal of the spare amp to the central unit
- 39: Speaker line 1A/1B 100V-amp input
Input to connect to the central unit the 100V-signal of the amplifier that feeds the speaker line 1
- 40: Speaker line 1A 100V-out / speaker line 1B 100V-out
switched 100V-Output for speaker line 1A/1B
- 41: Speaker line nA / nB 100V-amp input
Input to connect to the central unit the 100V-signal of the amplifier that feeds the speaker line n
- 42: Speaker line nA 100V-out / speaker line nB 100V-out
function identical to (19) for speaker lines 2 ... 8
- 43+44: Futur I and Futur II
Connectors for futur extensions
- 45: Connection terminal bus EVA 16 SYS 80CH

NOTE: all the phoenix plugs needed for the system-setup are included and come with the unit.

2.1.6 REARVIEW EVA LINE

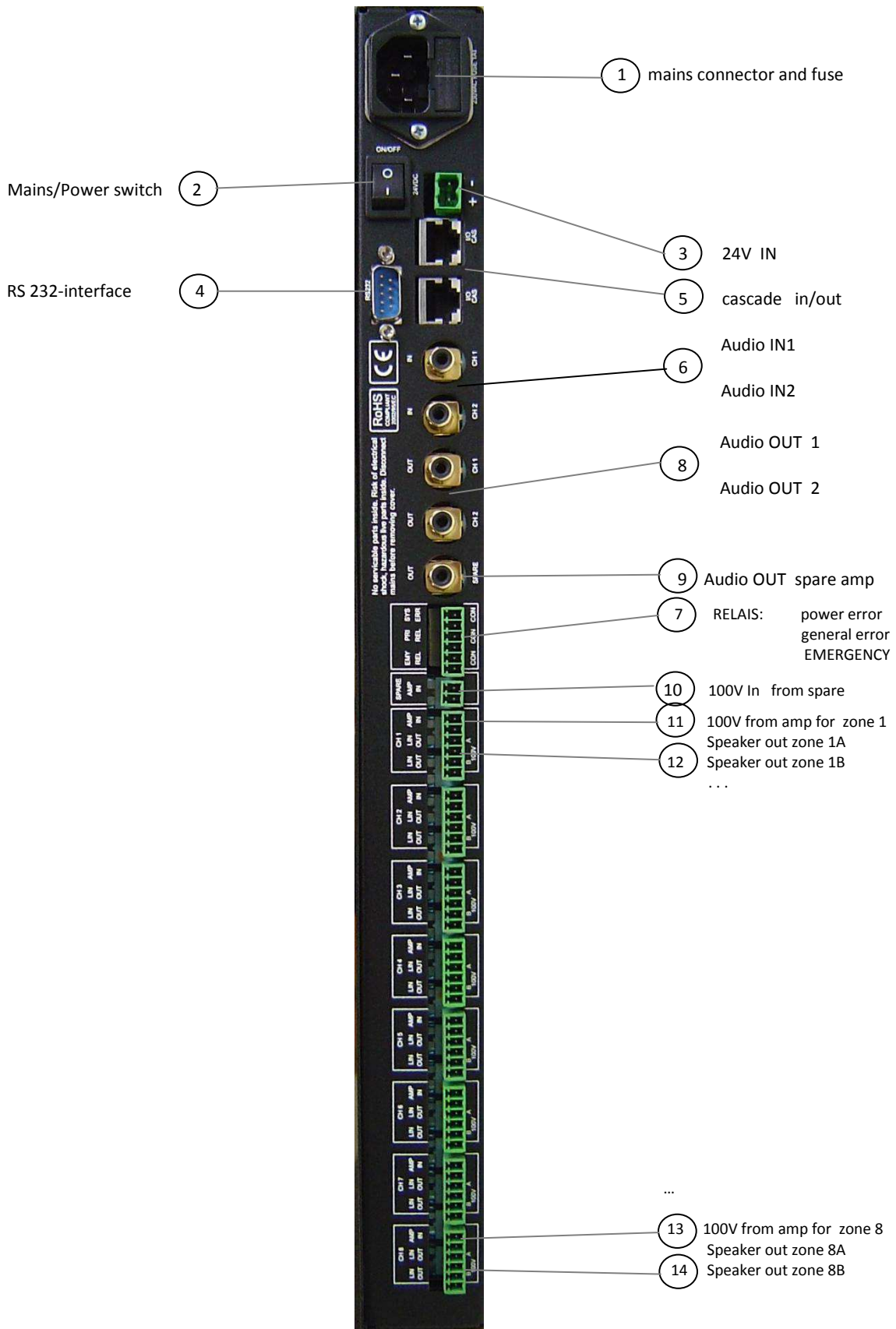

Functions and connection similar to EVA 16 M/S :

- 1: mains connector 230 V:
- 2: mains switch ON / OFF :
- 3: 24V connector :
- 4: RS232 interface D-Sub 9pin(m) :
- 5: cascade RJ45-connector :
- 7: error relais : general / emergency / supply
- 9: audio out to spare amp
Transformer balanced audio line-output to spare amp
- 10: incoming 100V from spare amp to the system
- 11: incoming 100V for speaker zone 1A / 1B
- 12: speaker zone 1A 100V-out / speaker zone 1B 100V-out
- 13: incoming 100V for speaker zone nA / nB
Similar to (11) only for zone 2...8
- 14: speaker zone nA 100V-out / speaker zone nB 100V-out
Similar to (12) only for zone 2...8

At variance with EVA 16 the following elements are present :

- 6: IN 1 / IN 2 :
Chinch connectors for audio line signals;
a signal fed to IN 1 is available in parallel at Out 1,
a signal fed to IN 2 is available in parallel at Out 2 .
- 8: NF 1 Out / NF 2 Out /
Transformer balanced, ground-lift, audio line-outputs,
to the 100V- zone amp(s).

NOTE: all the phoenix plugs needed for the system-setup are included and come with the unit.

2.2 SMALLEST POSSIBLE SYSTEM CONFIGURATION

For the smallest possible system setup of an EVA 16 M system compliant to EN 60849 two channels of 100V-amps have to be provided.

One amp channel as standard zone amp, one as a spare amp.

The line-input of the standard amplifier will be connected to one of the outputs Out CH1 ... Out CH4 of the EVA 16 M (f.e. Out CH. 4).

The 100V-output of the standard-amplifier feeds the input connector of the desired output-relay. (f.e. relay CH8)

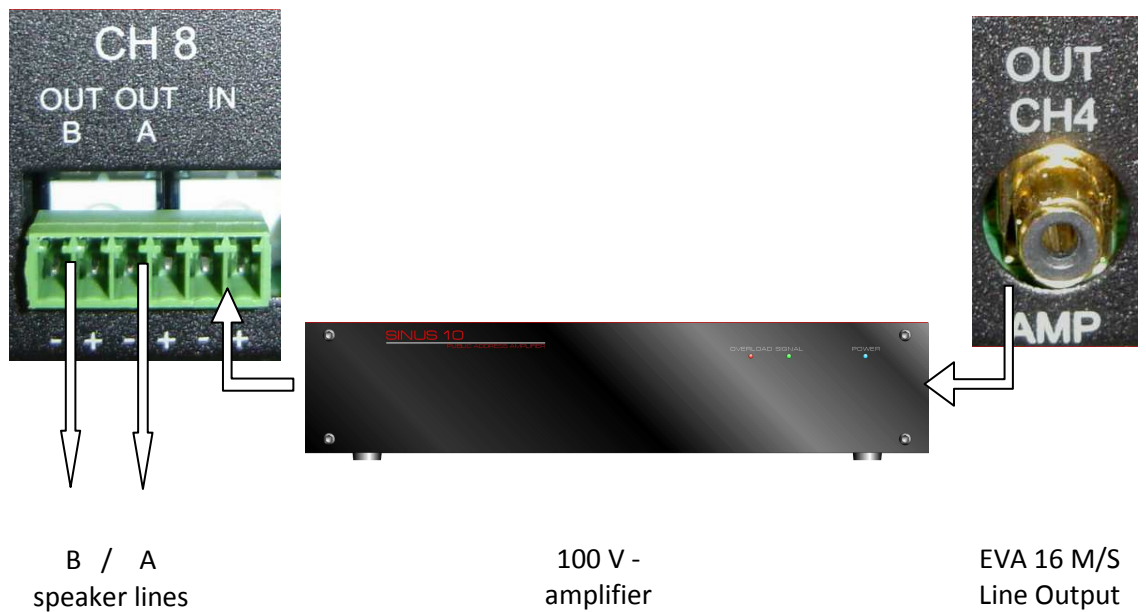

The input of the second amplifier (spare amp) will be connected to the spare amp output (OUT SPARE) of the EVA 16 M.

The 100V-output of the spare amp will be connected to the input connector for the 100V-spare amp signal. (SPARE AMP)

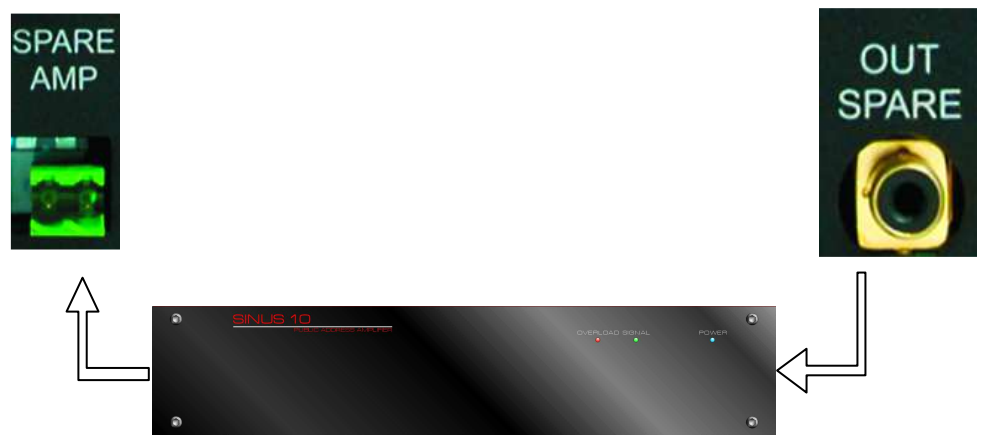

2.3 THE MP3-MEMORY CARD (EVA 16 M RESPECTIVE EVA 16 S ONLY)

Inside the unit there is a card slot for standard SD-flashcards .
(units produced before april 2009 may be fitted with MMC-cards; when replacing memory-cards please check the proper ALARM-function of the system; due to changes in technical specifications, the use of MMC-cards produced after 2008 is not possible).

All voice-messages and signal tones of the system are stored as *.mp3 on the SD-Card. The recommended data rate is 256 kBit/sec, 44kHz mono, but it's possible to use other formats.

**CAUTION : the exchange of the memory card is only allowed to be handled by authorized personal; the unit has to be opened.
For this, the EVA 16 M/S has to be turned off (mains and battery)
Inside of the unit dangerous voltages may occur ! Risk of electrical shock !**

The storing of the files to the card can be performed by a WINDOWS®-PC. The filename has not to exceed 8 characters, followed by ".mp3" . Every position has to be provided. The position of the files on the memory card has mandatory to be replicated as described in the following :

- 1.) 16KHz - testtone
- 2.) chime (call)
- 3.) alarm 1 - message
- 4.) alarm 2 - message
- 5.) alarm 3 - message
- 6.) alarm 4 - message
- 7.) text 1 – message
- 8.) text 2 - message
- 9.) chime (break)
- 10.) Fire – Gong (starting with firmware 4.0 or higher)

NOTE: WINDOWS®-Explorer may show the position of the mp3- files not in their physically arrangement but depending on the criteria of sorting.

To arrange the files in the recommended position, please handle them as described in the following :

1. After making a backup of the files clear the SD-card completely !
- 2.1 Copy the first source-file (f.e. „16KHz.mp3“) in „drag & drop“ – manner to the SD/MMC- card
- 2.2 Copy the second source-file (f.e. „2CHIME.mp3“) in „drag & drop“ – manner to the SD/MMC- card
- ...
- Continue like described until
- ...
- 2.10 Copy the last source-file (f.e. „firegong.mp3“) in „drag & drop“ – manner to the SD/MMC- card.

The correct position of the files on the card may be checked on EVA 16 M/S :

- Push red button [**PRG**], then,
- Push button [**T4**]

The system will show sequentially the number and the name of the corresponding MP3-file.

Even in normal use, EVA16 M/S shows the number and the name of the actual replayed audio file.

EVA 16 M/S uses the 16KHz-testtone for selftest purposes. Mandatory, the included original test file has to be used on the first position on the SD-card (the original 16 KHz-file comes with the system).

2.4 PRIORITY – ADMINISTRATION (EVA 16 M RESPECTIVE EVA 16 S ONLY)

The following priority structure has been accomplished for the audio-sources :

1. fire mik1 (call)
2. fire mik2 (call)
3. emergency call of EVA16 TER (... SYS TER) (call)
4. alarm 1
5. alarm 2
6. alarm 3
7. alarm 4
8. aux1
9. text1
10. EVA16 SYS 80 (... TER 80) (call)
11. EVA16 SYS 4 (... TER 4) , EVA16 SYS 2 (... TER 2) (call)
12. Break-Chime
13. aux2
14. text2
15. music 1 – 4

At the microphone-desks EVA16 SYS 4 and EVA16 SYS 2 the condition „occupied“ will be indicated by fast blinking of the („BESETZT-LED“), during this, there can not be given a call from such a desk to the system

At the microphone-desk EVA16 SYS 80 the condition „occupied“ will be indicated by the word („BESETZT“ = occupied) in display, respective a litten red LED-ring at the microphone; durinh this, there can not be given a call from such a desk to the system; except an emergency call or an alarm (ref. to the priority-list)

A microphone desk EVA16 SYS 2/4 connected to a slave system may give a call inside the slave system simultaneous to a EVA16 SYS 4/2 in the MASTER-SYSTEM or in another SLAVE-SYSTEM.

There will be no bilateral influence .

The “BREAK” – chime, AUX2 und TEXT2 do not cause a „occupied“ state in the system.

3. EXTERNAL COMPONENTS :

3.1 STANDARD – MICROPHONE-DESKS : (EVA 16 M RESPECTIVE EVA 16 S ONLY)

Before powering-up the system, please connect all external microphone to the I/O-board considering the correct pinout; careful connect the shielding !

Use a CAT5-cable and a 25pin SubD-cable to connect the I/O-board to the main unit EVA 16 M (ref. 3.3)

The second RJ-45-connector on the I/O-board is only mentioned for the use with patchcables. In this case, the total length of this cable should not exceed 30-40m.

On larger distances please use shielded cable 4x2 cores with a minimum diameter of 0,8 mm or more. A properly planned and assembled wiring allows distances for more than 100m ...

With the installed microphone desk, please check the voltage at the microphone connector by measurement. If the voltage drops lower than 14 V you have to use larger cable diameters (maybe in doubling some lines) or using an external power supply 15~24 V DC (permanent monitored, supported by a backup power supply ...)

Take care of using the right addresses for microphones.

A maximum of 8 addressed terminals can be connected to a system

No address has to be used more than one time;

Terminals with address 00 are not monitored.

Do not push any buttons before or during the installation run. This may cause incorrect identification of the units.

Variation of selected address not take effect until a new installation run was made.

Before that there will be no error messages or similar ...

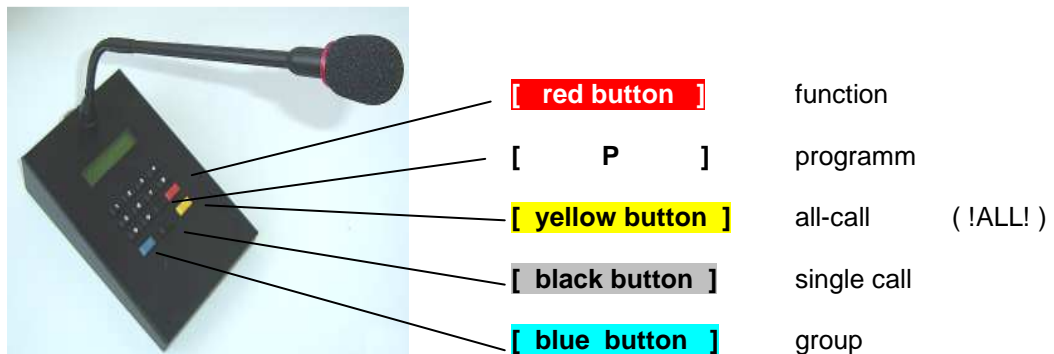

Desktop microphone station with LC-Display (2x20 characters)

10 numbered buttons and 5 function-buttons.

Call-zones may be named.

On a programmed address different to zero/0, ALARM 4 can be triggered; in this case, the request lines of the desktop station are supervised

Optional: switching music on/off of system music

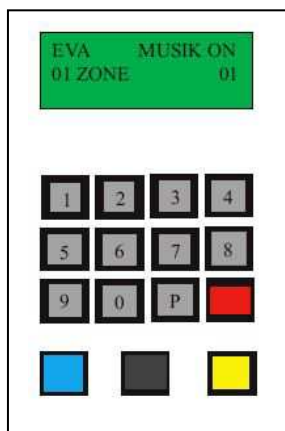

- the [blue button] triggers a predefined group-call
- the [black button] triggers a single-zone call to a preselected zone by the numbered buttons [0] ... [9]
- the [yellow button] triggers an ALL-CALL; this is unconditionally a call into every zones/lines
- the function of the [red button] depends on the programming. In default, there is no function at all.

programming:

By pushing the button [P] you will reach the PROGRAMMING-MODE.

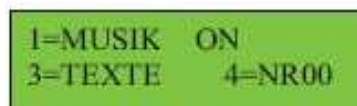

Example: display in PROGRAMMING-MODE

Functions :

Button [1]

Pushing the button [1] turns the music in the system ON / OFF. This is a common feature for all music inputs "music 1" .. "music 4" at the same time.

After pushing the button [1] , the microphone desk returns immediately to standard mode/display.

Button [3]

Pushing the button [3] will set the system into TEXT-MODE. Now you can give names to the first 40 call-zones. In the display, the following text appears:

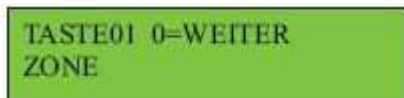

TASTE01 0=WEITER
ZONE

Example Display in TEXT-MODE

The call-zone 01 in default is named as 'ZONE 1'.

To enter a new zone name, use the keyboard - similar like using the keyboard of a mobile phone on writing SMS - as follows :

Buttton 1: A B C D	Buttton 2: E F G H
Buttton 3: I J K L	Buttton 4: M N O P
Buttton 5: Q R S T	Buttton 6: U V W X
Buttton 7: Y Z , :	Buttton 8: 0 1 2 3 4
Buttton 9: 5 6 7 8 9	
Button [P]	moves the cursor

Push the **[red button]** to return

Button [4]

Setting the address of the microphone:

On default, the address is set to "0". There is no supervision of any function of the desk. The address can be modified to "1" to "8". Programmed to an address from "1" to "8", the data line of the desk is supervised; "ALARM 4" now can be triggered from the desk. All desks have to use different addresses.

After any change of addresses, system needs an installation run.

ATTENTION : only for technicians !

Change the address of the desks in PROGRAMMING-MODE :

- push and hold Button [4] ... now adding
- push and hold Button [P] ... then
- release Button [4] ... then
- release Button [P]

While this procedure, the address increases by 1. To reach address 3, you have to do this 3 times ... Number 08 will be followed again by number 00.

After 5 seconds with no input, the system returns to the standard-mode.

Starting an ALARM :

Push and hold the **[red button]**; in display will appear as follows :

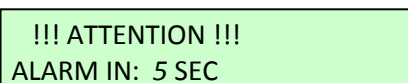

!!! ATTENTION !!!
ALARM IN: 5 SEC

Keep on holding the **[red button]** for 5 seconds, ALARM 4 starts and the display shows :

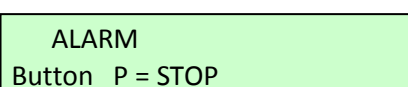

ALARM
Button P = STOP

The alarm can be stopped by pushing the button [P] again.

3.1.2 EVA 16 TER (EVA 16 M RESPECTIVE EVA 16 S ONLY)

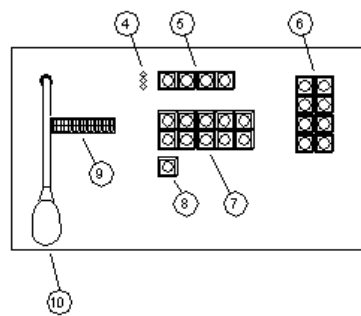
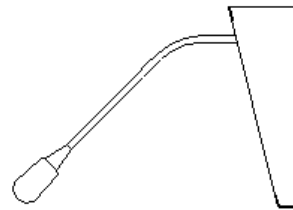
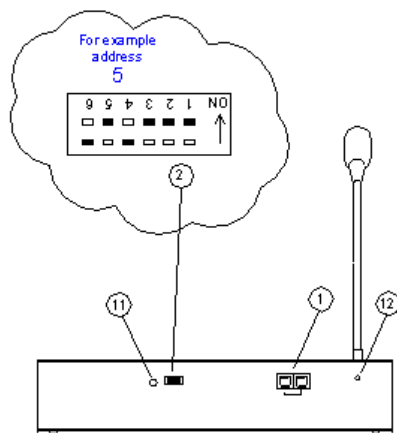

- ① Connector (RJ45)
- ② Address DIP-switch
- ③ Status LEDs
- ④ Grouped call button
- ⑤ Protected function keys
- ⑥ Dial keys
- ⑦ Call button
- ⑧ Display
- ⑨ Microphone
- ⑩ Connector for external power supply
- ⑪ Microphone volume control

Selecting the menu language by pressing and holding on of the buttons 1 (german), 2 (englisch) oder 3 (french) during power-up/connecting to the bus.

Description

Processor controlled desktop-microphone with gooseneck and integrated preamplifier to reproduce an optimized speech clarity.
Announcements selectable to any speaker-zone

LC-display with 2x20 characters to monitor the actual system status.

10 numbered, programmable buttons, programmable group button [A], all-call-button [B], 8 covered buttons for special security functions, green push-to-talk button (PTT),

(Buttons [C] and [D] provide no functions at the moment)

Three (3) LEDs (Power / Busy / Fault),

System functions and mic-capsule supervising comply to DIN EN 60849 (VDE 0828). Internal supervision of data line and microcontroller function.

All buttons on desktop station and corresponding functions programmable on EVA 16 M master unit; f.e.: turning on/off music completely.

Programmable user-specific groupings like Allcall, Groupcalls and Emergencall - including their correspondent priority levels. - All safety-relevant buttons covered .

RJ45-connector on the rear; using RJ45 Installation-wiringboxes and 8-wire cable (E30) to connect to the I/O-board; then connecting to the master via 25-pin D-Sub and RJ45 connector.

Setting of an unique terminal - address on the DIP switches: there is a maximum of 8 different addresses.

function of DIP-switches on the back of the enclosure :

ON: moveable element in direction of the arrow: to the top of the unit

OFF: moveable element against direction of the arrow, to the bottom of the unit

<i>Nr</i>	<i>Funktion</i>	<i>Beschreibung</i>
1:	no function	
2:	no function	
3:	function of the Button [<i>Hupe/Musik on/off</i>]	<p>ON: the buzzer inside the unit is deactivated the button turns off all the music inputs (4) of the EVA 16 M/S commonly.</p> <p>OFF: the buzzer inside the unit is enabled If an error occurs, the button can kill the buzzer-sound.</p> <p>[ATTENTION : the buzzer can not be reactivated until the system will be error-free ! If an error disappears and it occurs again, or an other error occurs, the buzzer will sound again.]</p> <p>audio-muting (<i>music 1 .. 4</i>) of the EVA 16 M/S is not possible.</p>

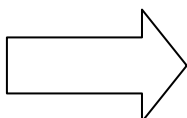

addressing the unit :

- 4: value ON = 0 OFF = 4
- 5: value ON = 0 OFF = 2
- 6: value ON = 0 OFF = 1

The added values of the activated dip-switches 4 .. 6 will give the address of the unit

Usable settings (rear view):

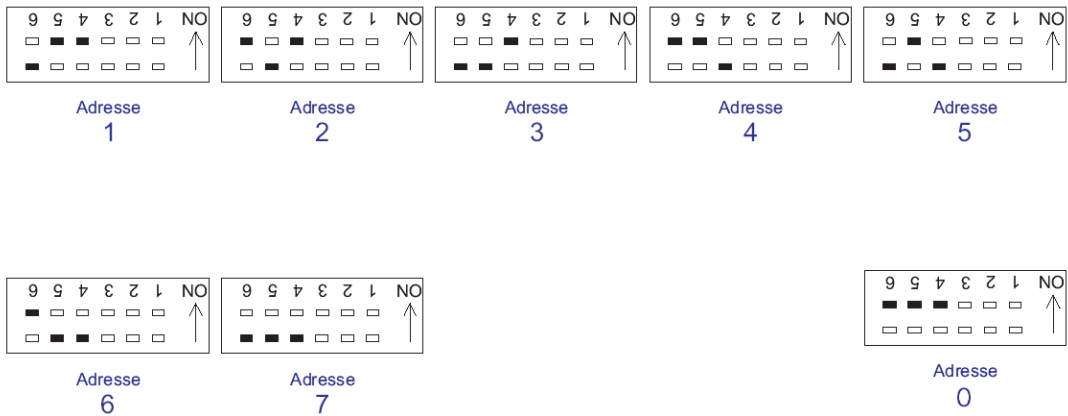

example: address = 5 , no siren <-> switchable music on / off

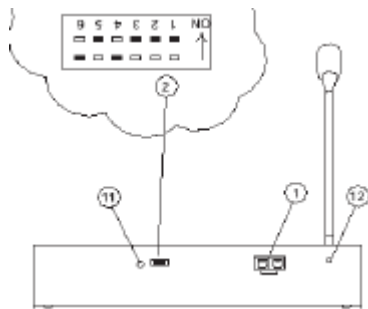

The EVA 16 TER terminal station allows the activation of special functions by the use of the cover-protected keys. To use this functions the sliding cover must be pushed down. This protection will automatically close again (two built-in springs).

So, these keys always are protected against unintended activation.

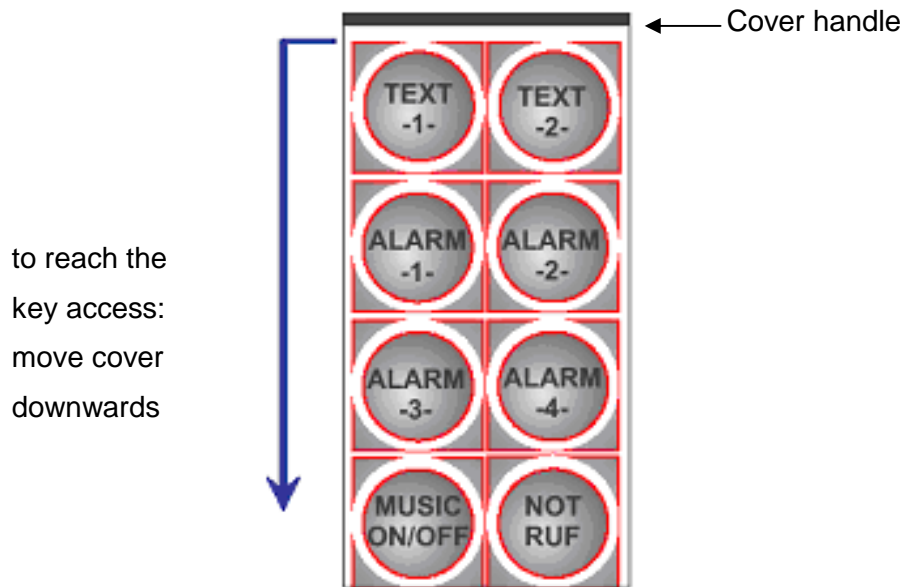

to reach the
key access:
move cover
downwards

Pushing the button
“TEXT 1” sends the
corresponding
audio-file once to
the preprogrammed
zones

Pushing the button
“ALARM 1” sends
the corresponding
audio-file endlessly
to the
preprogrammed
zones.
A second push
stops the ALARM

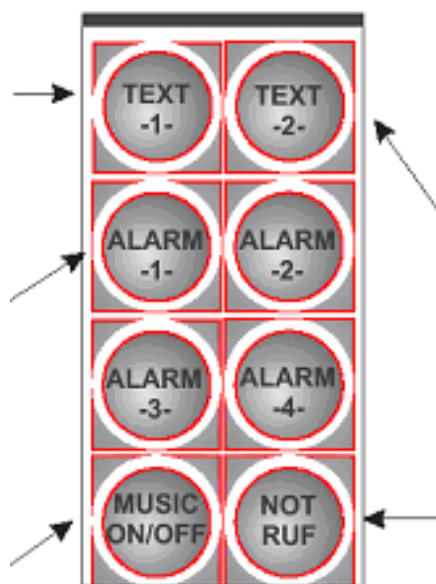

Pushing the button
“TEXT 2” sends the
corresponding
audio-file once to
the preprogrammed
zones

While pressing the
EMERGENCY CALL
a high priority call
will be transmitted
into all connected
speaker lines

The function of the lowest button in the left column depends on the programming:

If DIP-switch Nr. 3 is in ON-position, then these button turns the complete music in the system ON/OFF.

If DIP-switch Nr. 3 is in OFF-position, then these button turns off the piezo-buzzer in the terminal for this actual fault-type; returning a fault of the same type – or appearing a new fault, so the buzzer starts working again.

(In this case, the desk-top microphone station comes with a second labeling se - buzzer ON/OFF - to replace the default type.)



Desktop mikrophone with gooseneck, passive
 4 line buttons, protected against humidity, "occupied"-LED,
 to connect to the low-level microphone-bus

wiring diagram / connection :

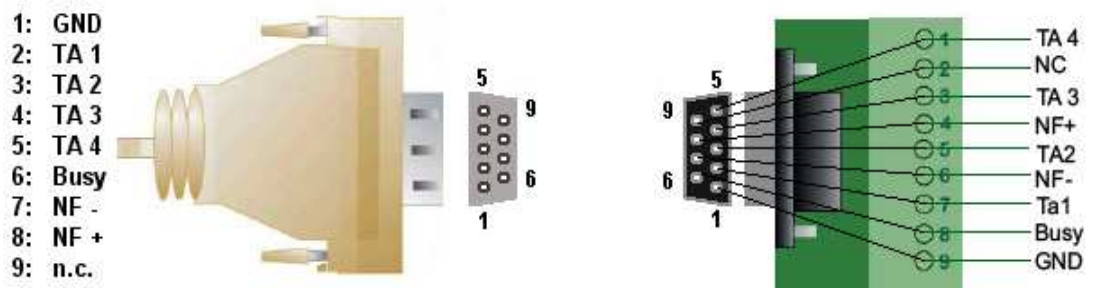

(TA means button)

terminal cable

| connector |

EVA 16 M/S

No programming required, this terminal is consequently passive.

The routing for the buttons TA1 .. TA2 has to be set in section SYS 4/2 on EVA 16 M/S.

3.1.4 EVA 16 SYS 2 - EVA 16 SYS 4+1 (EVA 16 M RESPECTIVE EVA 16 S ONLY)



Desktop microphone with gooseneck, passive.

EVA 16 SYS 2 (... TER 2) : 2 line buttons, "occupied"-LED,
 EVA 16 SYS 4 (... TER 4) : 4 line buttons and an all-call, "busy"-LED,
 (the all-call button is a hardwired addition of all 4 line-buttons)
 to connect to the low-level microphone-bus

wiring diagramm / connection:-

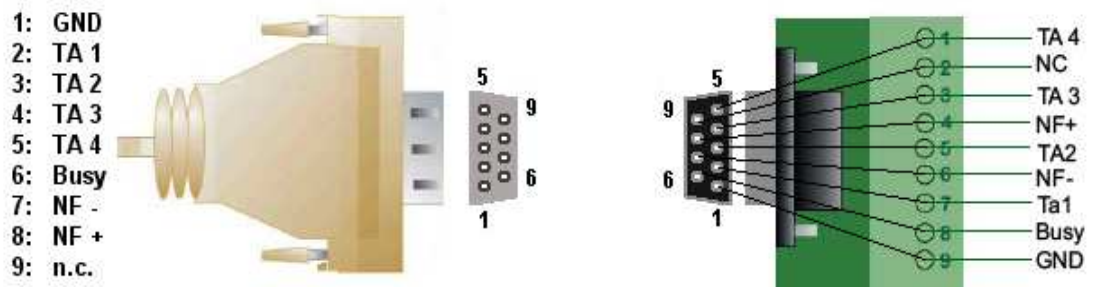

(TA means button)

terminal cable | connector | EVA 16 M/S

No programming required, because this terminal is consequently passive.
 The routing for the buttons TA1 .. TA4 has to be set on EVA 16 M/S.

3.2 FIRE - MICS :

3.2.1 EVA 16 SYS FT (EVA 16 M RESPECTIVE EVA 16 S ONLY)



Desktop fire-microphone with gooseneck, for emergency calls - compliant to IEC 60849,

Includes integrated circuit to be supervised by the central unit EVA 16 M/S

No EN 54-16 certification ! (ref. EVA 16 FP 3.2.3 ff)

wiring diagram / connecting :

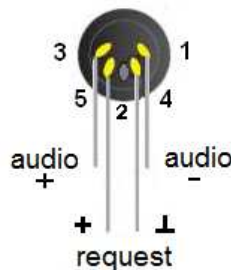

Pin 1: audio (-)

Pin 2: n.c.

Pin 3: audio (+)

Pin 4: Request (GND)

Pin 5: Request

connector wiring EVA 16 SYS FT (... TER FT) DIN 5pin
(view onto soldering side of connector / frontview EVA 16)

Absolutely consider the indicated polarities; a connection deviating from this pattern can lead to error messages or disturbances!

Only one firemic at a time allowed for the connector on the front panel, the firemic1 connectors on the back panel or the firemic1 port on the I/O extension card (including EVA 16 FP FirePanel)

No programming required, because this terminal is consequently passive;
the routing for the buttons TA1 .. TA4 has to be set on EVA 16 M/S.

3.2.2 EVA 16 SYS FH

(EVA 16 M RESPECTIVE EVA 16 S ONLY)



Handheld microphone with push-to-talk button, for emergency calls compliant DIN/EN 60849

includes integrated circuit to be supervised by the central unit EVA 16 M/S

mounting of a steel bracket is possible at the front plate of the EVA 16 M/S.

pinout :

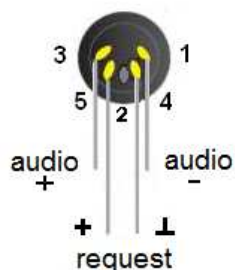

Pin 1: 0 V / GND

Pin 2: n.c.

Pin 3: audio (+)

Pin 4: n.c.

Pin 5: request

Pinout: DIN 5pin

(view onto soldering side of connector / frontview EVA 16)

The microphone terminal only can be connected to an EVA 16 M Master

Please pay attention to the shown polarities; variation may cause error messages.

Only one firemic at a time allowed for the connector on the front panel, the firemic1 connectors on the back panel or the firemic1 port on the I/O extension card (including EVA 16 FP FirePanel)

No programming required, because this terminal is consequently passive.

On EVA 16 M/S the routing for the push-to-talk button has to be set in the Fire-Mic programming section

3.2.3 EVA 16 FIRE PANEL



The FirePanel can be alternatively installed instead of the EVA 16 Fire Mik1.

The requirements of the EN54-16 are fulfilled.

The EVA 16 FirePanel optical matches the DIN14661
(Fire service control panel)

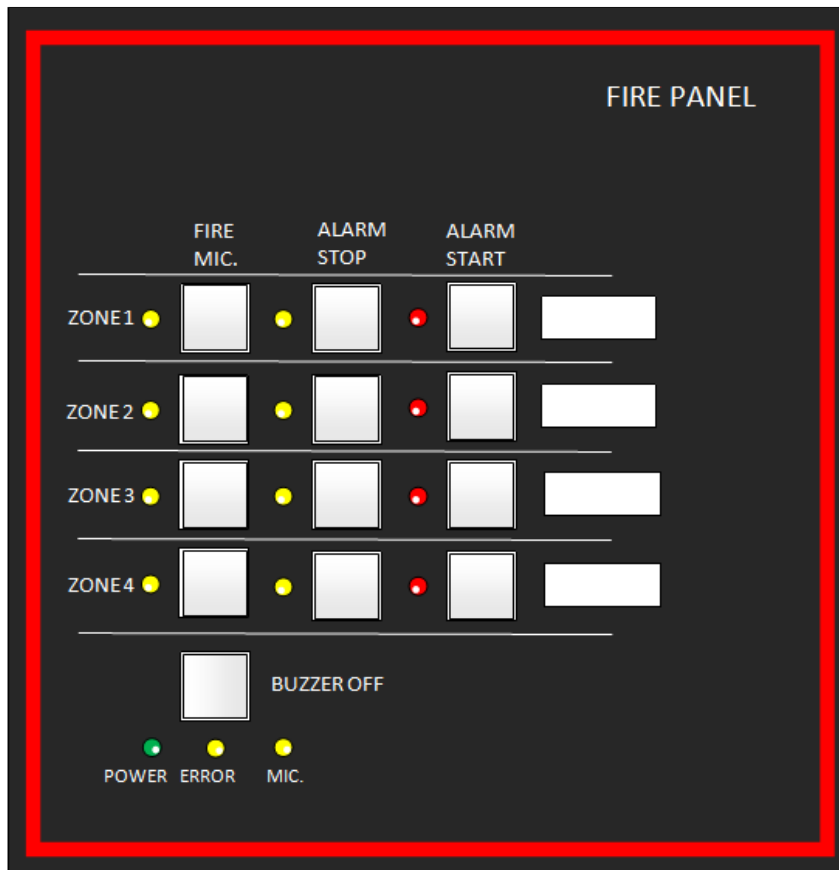

Control elements:

4 LED indicated switches; for starting the emergency call in up to 4 programmable emergency zones of the EVA 16 M/S. (Programming:..... go to AUDIO/LEVEL, then go to TEXTE/AUX/ALARM - then go to FIRE PANEL 1..4 ...)

6 LED indicated inputs for connecting to a fire alarm system.
(4 emergency zones, alarm all, alarm stop)

4 LED indicated switches; for stopping (reset) the emergency calls.

4 LED indicated switches; for the zone selection of the fire service microphone.

Press the hand-held microphone`s button to start a call.

1 LED indicator, standby

1 LED indicator, error

Deviant to the actually norm (EN60849), the identification color for emergency calls is red, for functionality and errors yellow and for system standby green.

The connections from/to the fire detection system must be controlled by the fire detection system.

The fire detection system supplies 24V for starting the emergency text. With the 24V, the relays of the FirePanel are triggered. Errors of the EVA16 system are signaled by a piezo buzzer and a LED indicator.

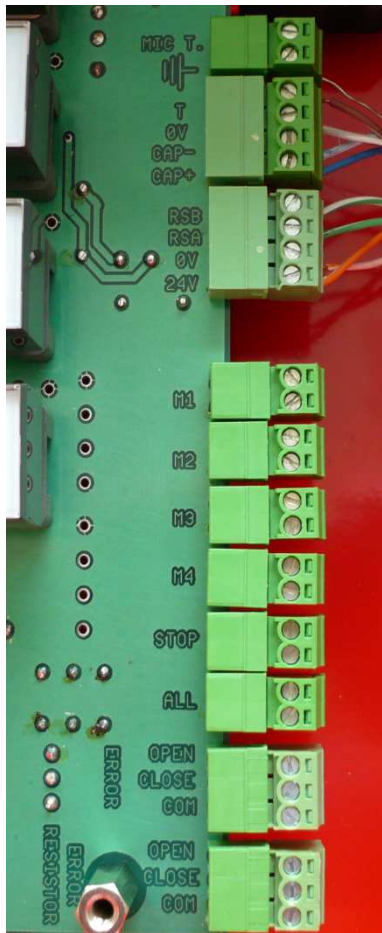

- MIC T.  Hand-held microphone button; only operating in Slave-mode. Shielding is necessary.
- T Unloaded 3,3V, otherwise data bus request- ground. (don` t connect with the system ground)
- 0V
- Cap -
- Cap + Microphone capsule
- RS B RS485 interface (only reception). In case of an emergency the "Anhalten" LED is lit, also if the fire mic2 is in use or if the EVA16 signals an error.
- 0V System ground
- 24 V Supply voltage
- M1 Relays for starting emergency signals by a fire detection system; 24 Volts between 2pins (coil 2000 Ohm, without a diode)
- ...
- ...
- M 4
- STOP Relays for stopping all running emergency signals by a fire detection system; 24 Volt 2pin (coil 2000 Ohm, without a diode)
- ALL Relays for starting all emergency signals by a fire detection system; 24 Volts 2pin (coil 2000 Ohm, without diode)
- ERROR Error relays. In case of anerror (even if the panel has no supply Voltage) the relay switches from COM to CLOSE.
- ERROR Resistor Error relays with resistor wiring.

In case of an error (even if the panel has no supply voltage)
the relays switches from COM to CLOSE.

For monitoring by a fire detection system connect the change-over contact as follows :

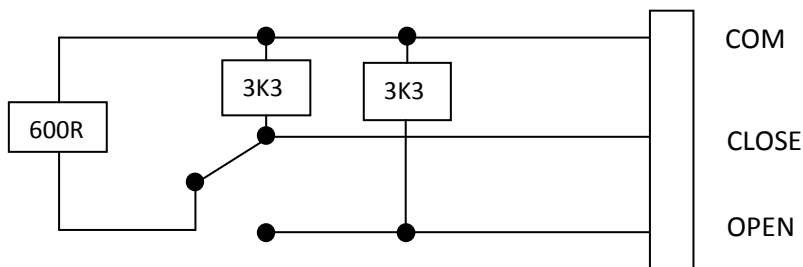

:

NOTES :

For each EVA 16 M or S there has to be used a separate EVA 16 FP FirePanel
(there are solutions with only one FirePanel together with more than one EVA 16 ;
please contact us if required)

For use of more than one system there is offered an integrated housing

To connect EVA 16 FP to the central unit EVA 16 M install the I/O port card for
use with EVA 16 FP .

Only one firemic at a time allowed for the connector on the front panel, the
firemic1 connectors on the back panel or the firemic1 port on the I/O extension
card (including EVA 16 FP FirePanel)

After installing the terminal performing of an installation run is required.

(ref. 4.1.1) pay attention that the EVA 16 M has to display : "FireMic1 installed" t.

For correct function, it's mandatory to reboot the whole system
(cutting 230V and 24V for a minimum of 5 seconds, then starting the system again ...)

That's the only way to ensure correct function of EVA 16 FP on EVA 16 M Master;
without rebooting, it may take 15 min. or longer for the system to recognize the FirePanel

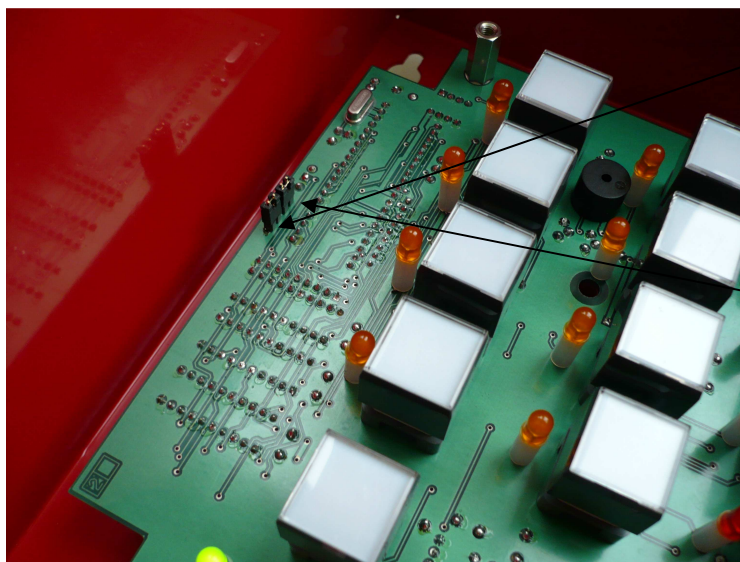

Jumper2:

after removing jumper2
the buzzer may sound
during an ALARM or a
mic call
(in case of an error)

Jumper 1:

after removing jumper1
external starting of
alarms will be delayed
for 10 seconds;
so a trigger for an
alarm has to be
present for a minimum
of ten seconds. !

also refer to the detailed

„installation Manual for FirePanel EVA 16 FP“

3.3 I/O-PORT (EXTERN)



This unit provides on an external board identical connections with identical naming separated from the rear panel of the master-unit EVA 16 M/S.

Furthermore the connection point for FirePanel is provided here.

There is an EMERGENCY RELAY (NOTFALL) that provides two (2) “normally closed” and two “normally opened” contacts. (CHANG-OVER); it switches during an active ALARM, a call on a FireMic or during installation run; so it may be used as an OBLIGATION RELAY (PFLICHTRUF).

There is an ERROR –relay that switches in case of a general ERROR in the system.

Once the CHIME (GONG) is triggered (pulse), it plays one complete run.

Once triggered (pulse), TEXT 1 and TEXT 2 play one complete run.

On a permanent request / start signal, TEXT n runs endlessly until the request terminates.

The I/O-Port will be connected to the master unit by a 25pin DSub cable and a CAT 5 – patchcable. The board can be included in an electric installation box.

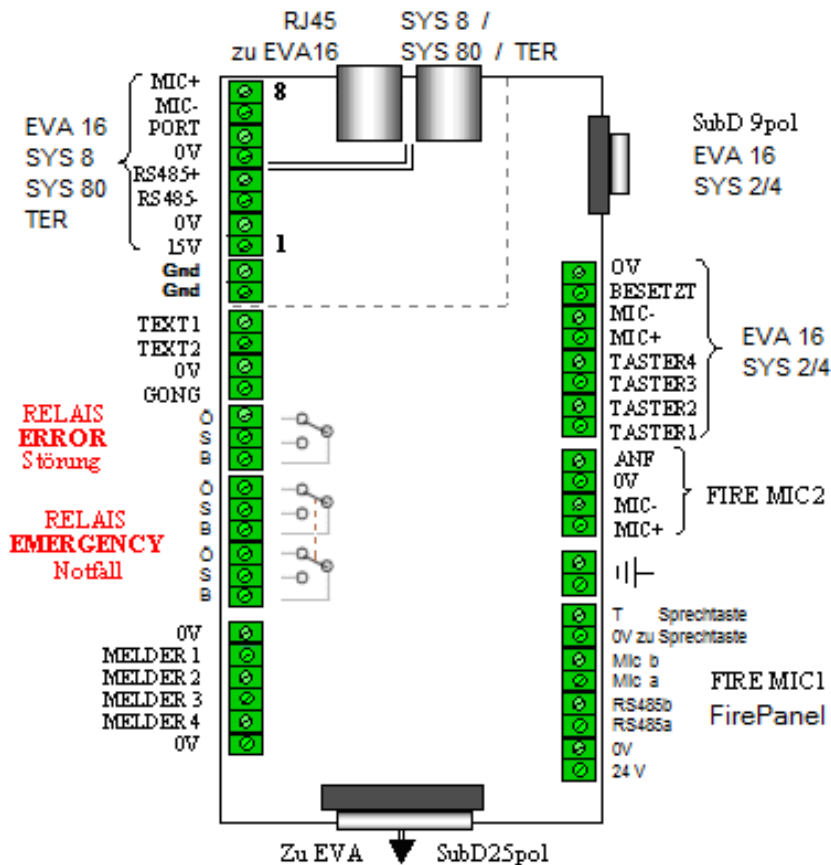

The microphone/terminal bus found on RJ45-plug will be swapped to standard installation cable (JY(St)Y 4x 2x 0,8 bzw. JEH ...) single screw connections

Contact points (take care by identifying the pin numbers)

:

- 1: 15 V
- 2: 0 V
- 3: RS 485 -
- 4: RS 485 +
- 5: 0 V
- 6: Port
- 7: Mic. -
- 8: Mic. +

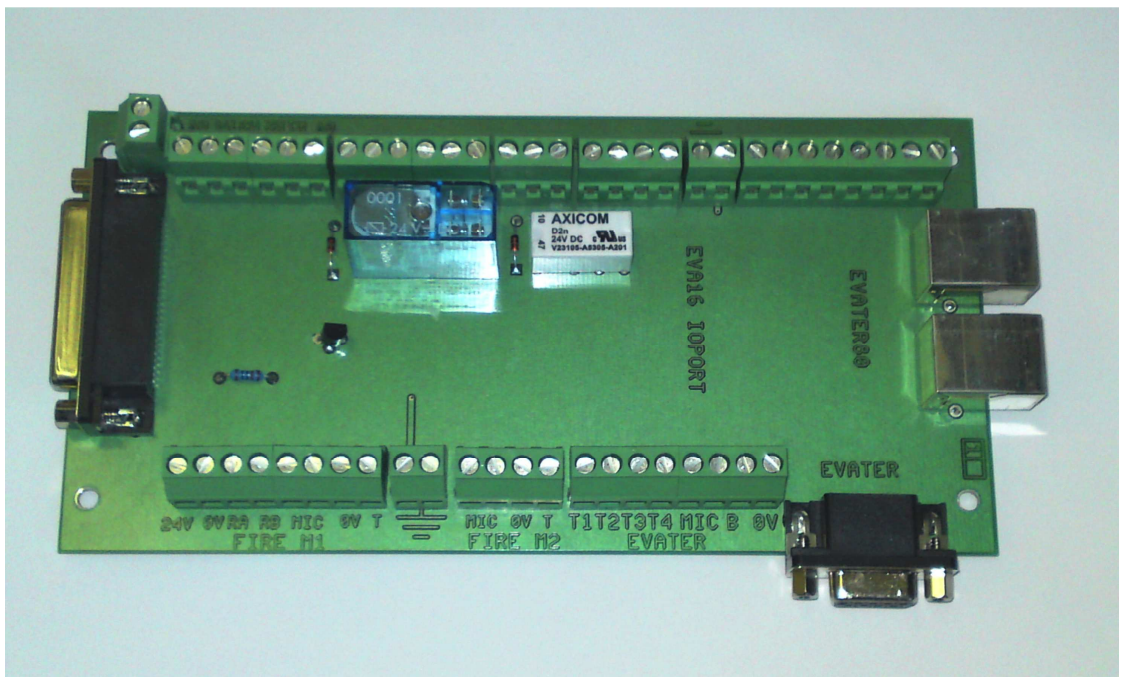

The connectors to FireMic 1 / FirePanel mean as the following :

T	push-to-talk-button / FirePanel FP- Data	
0V	reference for PTT-button / data	
Mic	coil b-line	
Mic	coil a-line	
RB	RS485-interface b-line	(FirePanel only)
RA	RS485-interface a-line	(FirePanel only)
0V	reference for supply power	(FirePanel only)
24V	power supply	(FirePanel only)

Do not connect 0V of power supply to 0V of push-to-talk-button data

3.4 CONNECTING THE ALARMCONTACTS

Alarm contacts can be connected both to the central unit and the I/O-board. In the following you find the description of the setup of an alarm contact.

A loop resistance of approx. 10kOhm is interpreted by the system as a functioning but not an activated alarm line; about 3.3 V DC line up at the reporting entrance.

Clearly higher tensions up to max. 5V DC the system interprets as a wire break in the loop and give an appropriate error message.

A loop resistance of approx. 5kOhm is interpreted as an activated reporting line released by the system as functioning. About 2.5 V DC line up at the reporting entrance.

Clearly lower tensions the system interprets as loop short-circuit and give an appropriate error message.

Alarmline 1: Use of the switch [ALARM 1] on the front panel :

Using alarmline 1 only with the switch [ALARM 1] on the front panel of the central unit, so an external resistor $R_a = 10k$ has to be installed (default),

In this case, this is the termination resistor of the alarm-line.

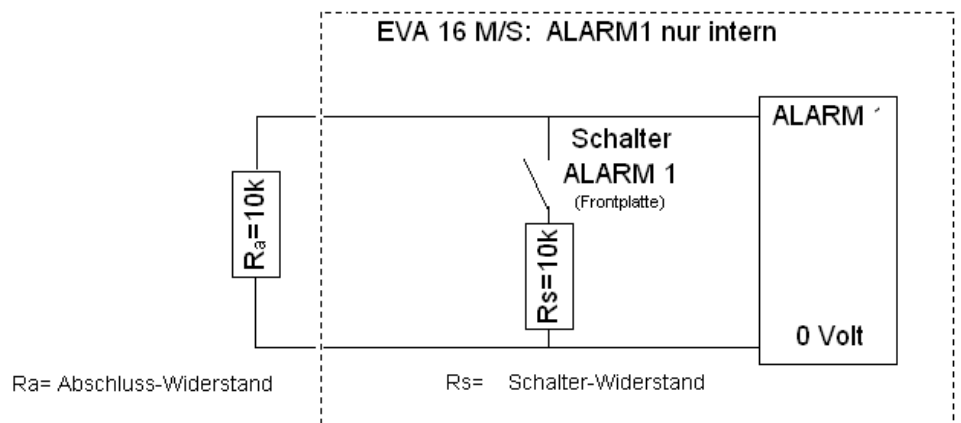

Internal switch "ALARM 1" mitwith additional external alarmbox:

If in addition to the internal switch ALARM 1 an external alarmbox is required, so the resistor $R_a = 10k$, installed on the back panel of EVA 16, has to be removed; the termination moves to the end of the alarmline to the external alarm contact. Two resistors 4k7 required as shown (illustration: example for wiring)

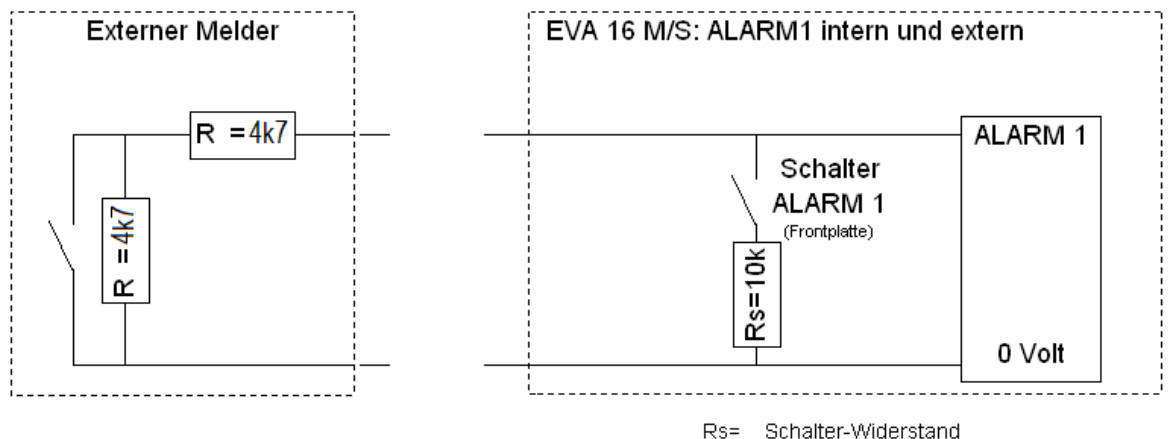

For use of more than one alarm-box on alarm-line 1, they have to be tied together as described as follows under alarm-line 2..4 :

Alarmline 2..4: connecting external alarm boxes

When using only a single alarm box on alarm line 2..4 wiring has to take place as described in the following :

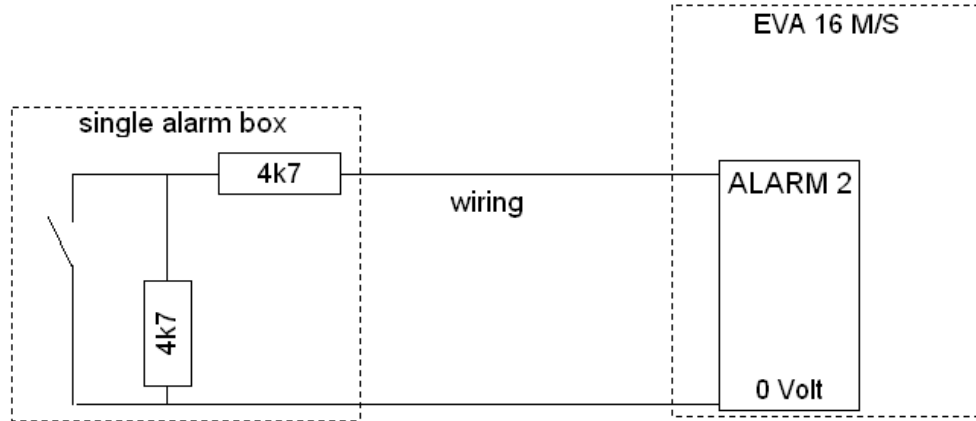

(for only one alarm contact there may be an alternative wiring with a terminal resistance $R_A = 10k$ and a second resistance $R_S = 10k$, switched from alarm unit contact parallel to the terminal resistance.)

Using more than one alarm-box in an alarm line, wiring has to be done as shown above for alarm-line 1.

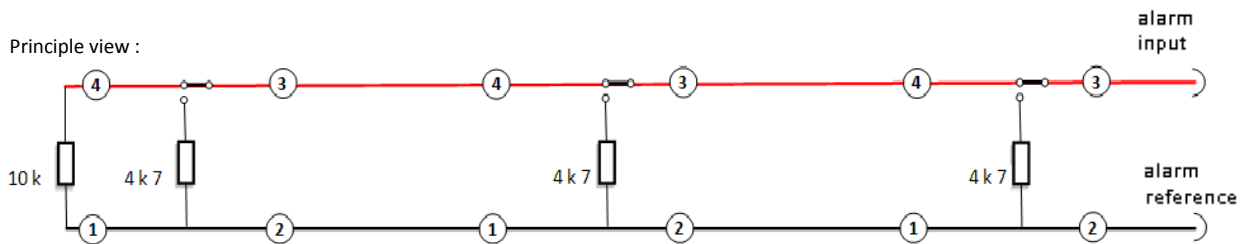

(the numbers shown in the figure refer to the connectors of the recommended alarm box G&M MLD BL or G&M MLD GB)

Special characteristics :

When an alarm-line will be cut after triggering an alarm signal (by fire f.e.), the playing of the message will continue. It only can be stopped at the central unit.

When an alarm-box started an alarm signal, it's failure can't stop the message replay.

3.5 EXTERNAL RELAY BOARD EVA 16 REL

The relay board EVA REL was developed to implement a lot of switching and additional features. It provides a lot of decoding functions for bus-signals or discret wired ports

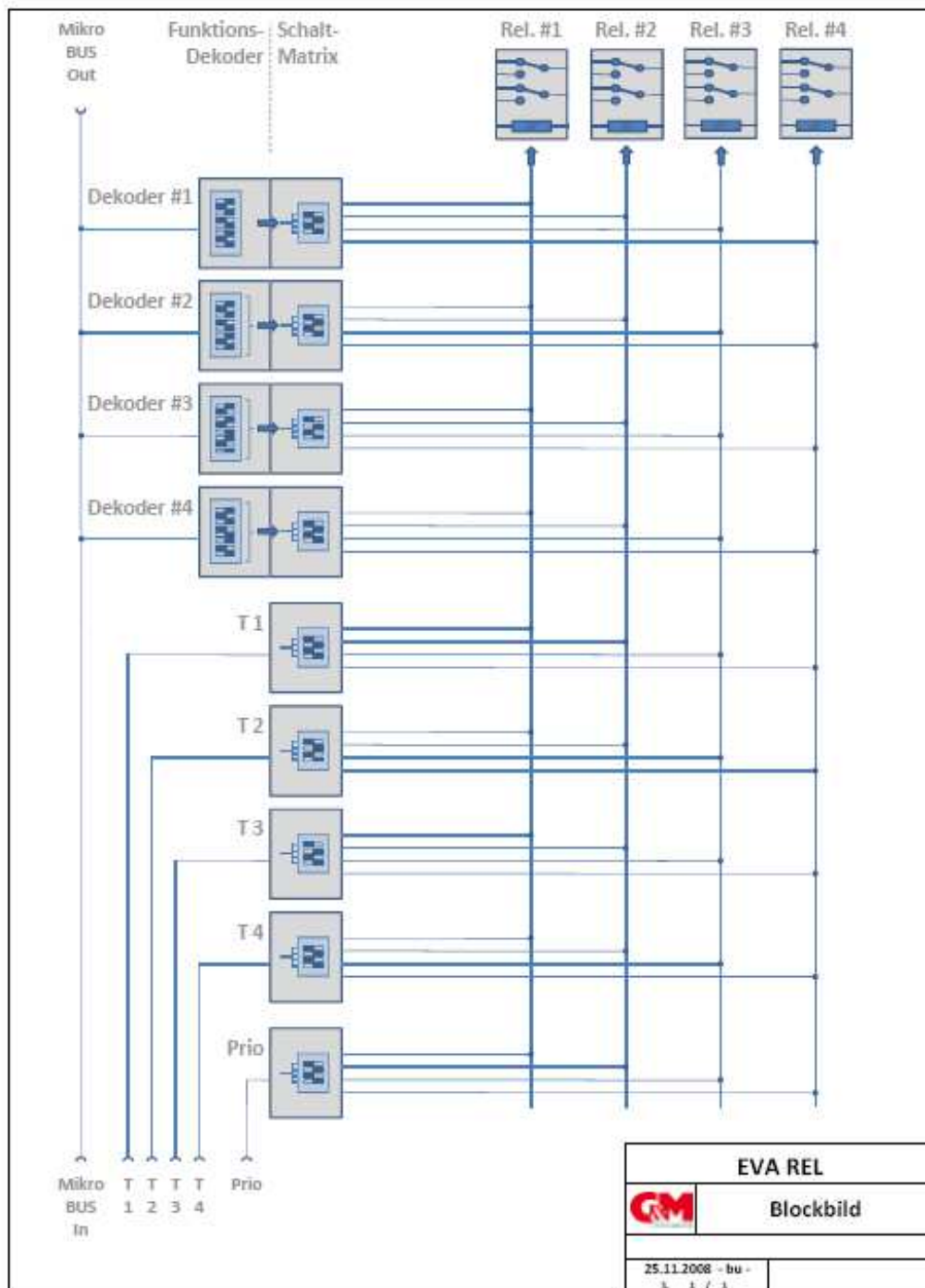

3.5.1 COMMON DESCRIPTION: RELAYBOARD EVA REL

The relay board **EVA REL** was developed to enhance logical and switching capabilities in relation to system central unit **EVA16 M**. It provides four (4) relay ports with two normally open / normally closed contact blocks each.

Connecting to the system may be in two different kinds:

Inserting into the terminal bus of a **EVA16 M** master using the two RJ45-connectors ; this provides necessary power supply for the active electronics (standard).

On the other way, buttons of simple terminals (f.e. **EVA 16 TER 2/4**) may be connected by single wired contact blocks (optional).

To drive the relays, an external power supply (DC24V-) has to be provided.

More than one relay board may be connected to the terminal bus.

3.5.2 DESCRIPTION :

The available relay board may assign altogether up to 10 selected switching functions to the 4 provided relay blocks optionally and independently.

A relay can take several switching functions; just as a switching function can be assigned to several relays around this; to reach this EVA REL offers the following functional modules are provided:

4x decoder „bus-function“,

each providing a functional decoder and a 4-way-switch matrix

1x decoder „global-function“

providing a functional decoder

5x decoder „contact-function“

providing a 4-way-switch matrix

4x relay blocks

equipped with dual turnover contact

(common / normally closed / normally open)

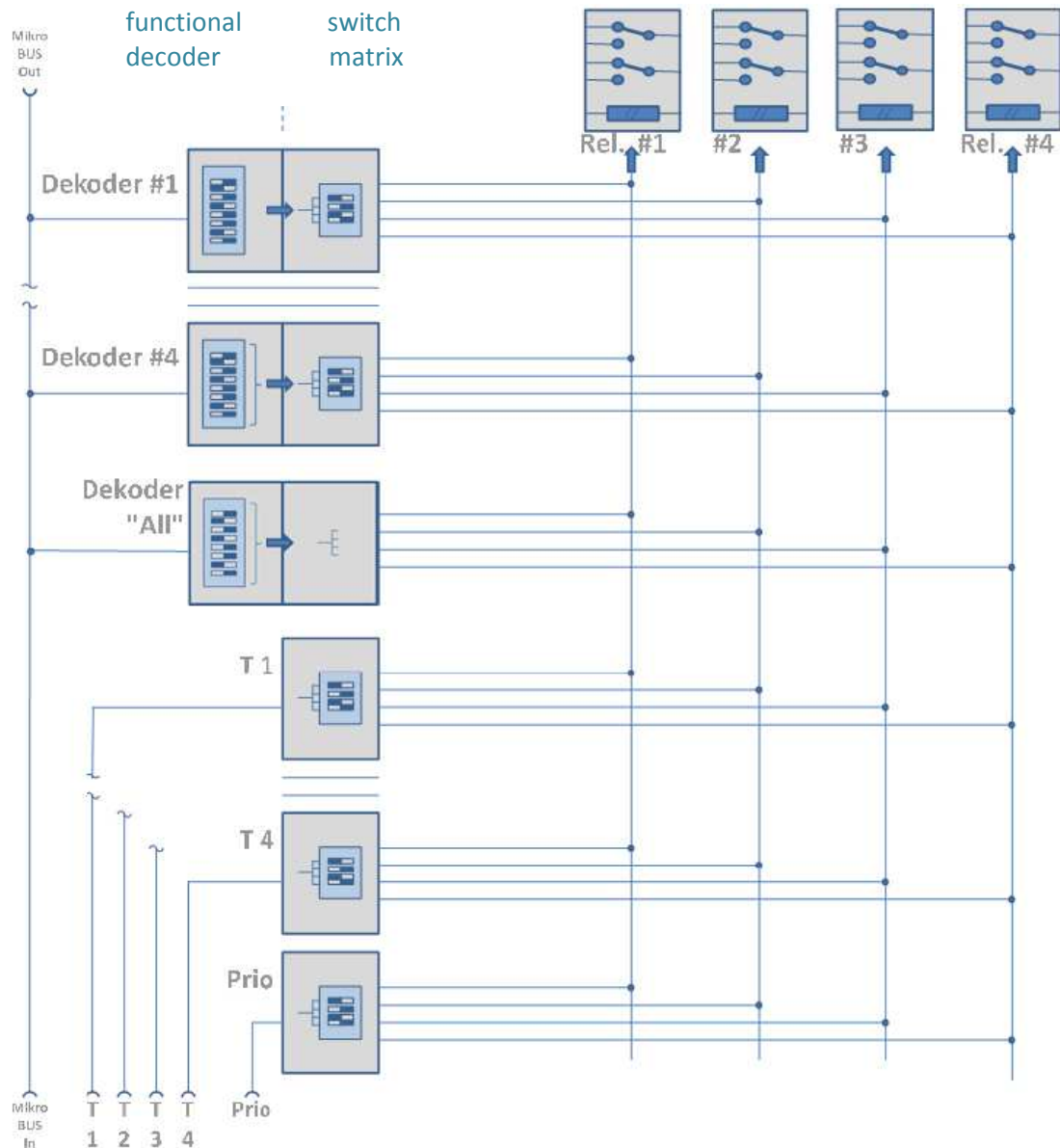
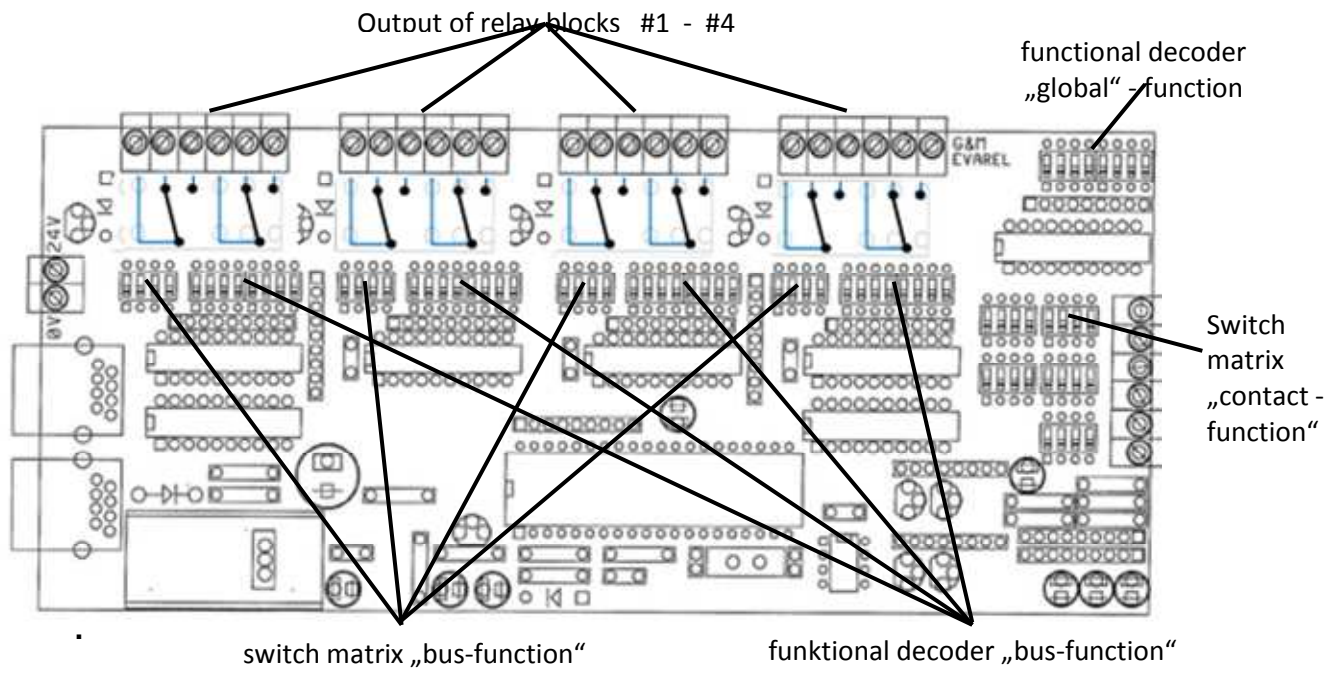

3.5.3 DECODER „BUS-FUNCTION“

Each of the four independent decoder units for „bus-function“ provides two groups of DIL-Switches:

A functional decoder and a switch matrix:

3.5.3.1 functional decoder „bus-function“:

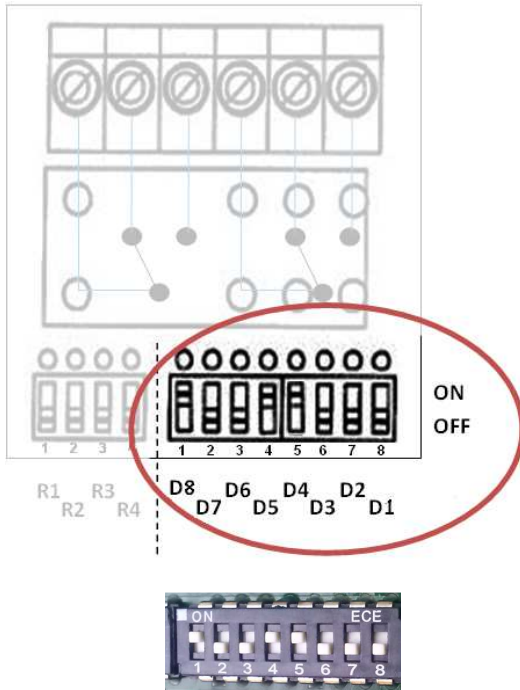

setting the DIL-switches as two parts of a byte selects the required activity from a list of permitted functions (ref. Appendix) ;

Example :

D8...D5 represent the higher part of the byte
D4 .. D1 represent the lower part of the byte;

The code for TEXT 1 is 98_{HEX} (1 Byte)
The setting would be 1001 1000

```
D8=1 / D7=0 / D6=0 / D5=1 //
  1   2   3   4
D4=1 / D3=0 / D2=0 / D1=0
  5   6   7   8
```

3.5.3.2 switch matrix of the „bus-function“:

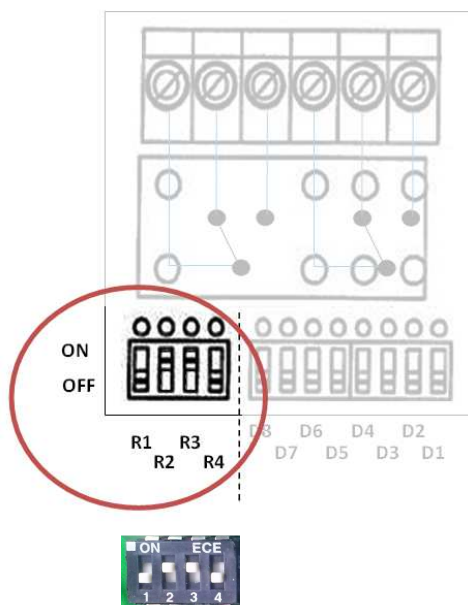

setting the DIL-switches as four independent channels, the selected function of the functional decoder above will be assigned to a configurable number of relays

Example :

R1 ... R4 represent the relay ports that may be related to the function

By R1=0 / R2=1 / R3=1 / R4=0
in this example an activated function would trigger *relay 2* und *relay 3* .

3.5.4 DECODER „GLOBAL-FUNCTION“

This part of the unit provides an eight-way DIL-switch unit:

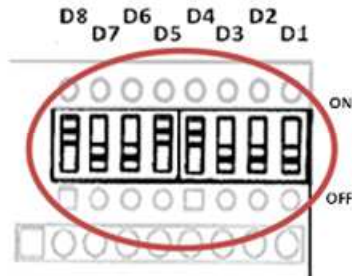

setting the eight DIL-switches as two parts of a byte selects the required activity from a list of permitted “global”-functions for triggering all four relays in common ; (ref. Appendix)

Example :

To trigger all four relays on activating

TEXT 1 (98_{HEX})

setting of DIL-switches D8...D5 / D4 .. D1

1 2 3 4 5 6 7 8

has to be as follows **1 0 0 1 / 1 0 0 0**

3.5.5 DECODER „CONTACT-FUNCTION“

This decoder provides five 4-way DIL-witches :

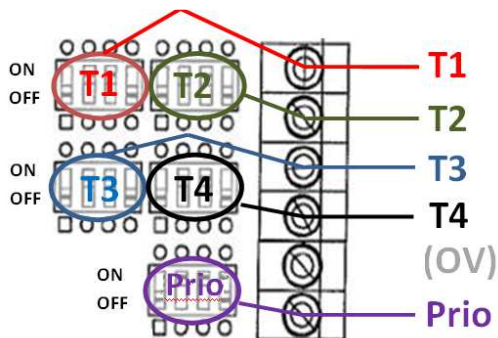

The ports *T1..T4* and *Prio* normally provide +5V. to activate a switching port, it has to be connected to 0V/Gnd. externally.

setting up the switches port by port (four switches represent one port) selects the relay to be activated by this port.

Example :

To trigger relay 2 by activating port *T4* the DIL-switches *R1...R4* of port *T4*

has to be set up as follows :

T4: 0 1 0 0 resp.. OFF / ON / OFF / OFF

Pushing button 4 / port4 can trigger a request to an external sound system

3.5.6 FOUR RELAY BLOCKS :

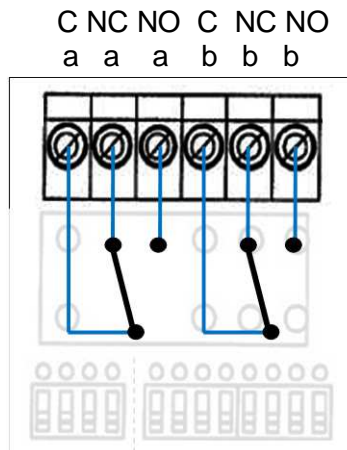

The relay card provides four identical relay blocks, equipped with dual turnover contact

common	Ca
normally closed	NCa
normally open	NOa
common	Cb
normally closed	NCb
normally open	NOb

3.5.7 POWERSUPPLY FOR RELAY BLOCKS

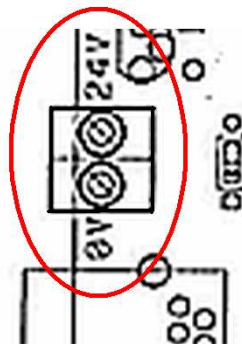

The 24V power supply for the four relays of the card will be connected by single screw connectors (+24V / 0 V). Please check for correct polarity.

3.5.8 CONNECTING DATA BUS

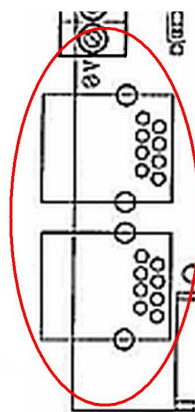

The connection to the microphone data bus works by RJ45 connectors. The signal may be carried through the card. More than one card EVA 16 REL 4 may be connected.

The power supply of the logical part of the electronics comes via RJ45-cable.

3.5.3 TECHNICAL DATA :

power supply logic unit	:	internal by EVA16 bus
consumption relais	:	external: 120mA / 24V DC
switching capability 100V-relay	:	Pmax. 800W/ 100V)
dimension	:	(w x d) 199x85 mm
weight	:	0,3 kg
housing	:	none, comes as printed circuit board
temperature range	:	-5°C<T<55°C

List of possible functions for functiondecoder / transferring to BCD-Code :

Attached you find the list of possible settings for the functions decoders .
There you find also the HEX-coded numbers listed :

<u>Example :</u>	EVATER80 ALL CALL	Code 00H
	Alarm1	Code 92H
	Text1	Code 98H

H stands for „HEX-coded“ number; the two positions (DECADE + SINGLE) will be coded separately,
Text1 98H f.e.: >9< and >8< . The coding refers to the following list :

HEX	BCD
1	0001
2	0010
3	0011
4	0100
5	0101
6	0110
7	0111
8	1000
9	1001
A	1010
B	1011
C	1100
D	1101
E	1110
F	1111

Beispiel : Text1 - Code 98H = mit 1001 (für >9<) und 1000 (für>8<) = 1001 1000

Appendix 1: List of selectable Functions for Functional decoders :

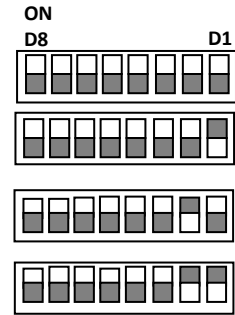

	EVATER80 general -call	Code 00H	0000 0000
	EVATER80 zone 1	Code 01H	0000 0001
	EVATER80 zone2	Code 02H	0000 0010
	EVATER80 zone 3	Code 03H	0000 0011
	
until	EVATER80 zone 80	code 50H	0100 0000

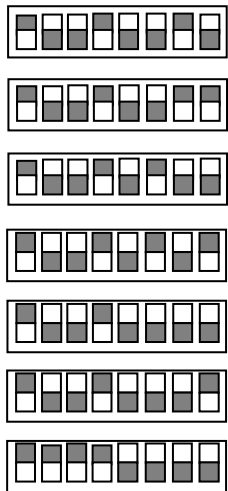

	alarm 1	Code 92H	1001 0010
	alarm 2	Code 93H	1001 0011
	alarm 3	Code 94H	1001 0100
	alarm 4	Code 95H	1001 0101
	fire Mic1	Code 90H	1001 0000
	fire Mic2	Code 91H	1001 0001
	EVATER80 all-call	Code F0H	1111 0000

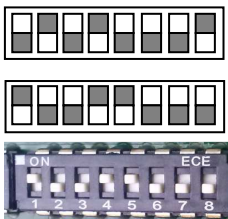

	AUX1	Code 51H	0101 0001
	text 1	Code 98H	1001 1000

Selectable codes for "bus-function" and for "global-function "

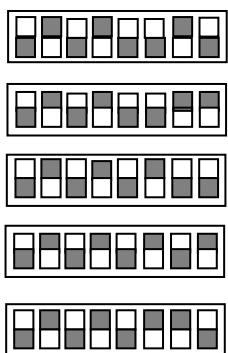

	EVATER80 global	Code 52H	0100 0010
	alarm + fire mics global	Code 53H	0101 0011
	alarm global	Code 54H	0101 0100
	fire mics global	Code 55H	0101 0101
	EVATER80+firemics+alarm global	Code 56H	0101 0110

Using the switches "GLOBAL" all relays were triggered by the selected function.

4.0 OPERATION

4.1 START-UP :

4.1.0 POWERUP / LANGUAGE SELECTION / FACTORY RESET

After turning on the unit, system comes up as follows : ...

```
language      V n.n
```

language stands for the selected language of the user interface / menus

... and 3 seconds later ...

```
V n.n      dd.mm.yy
```

V n.n is the installed firmware release

dd.mm.yy : date of release of the installed firmware

... to reach the following display content after another 3 seconds :

```
ZONE 1:      MUSIK 1  
SYSTEM_OK   EVA16M
```

normal view

Language :

Selection of the language takes place by pushing and holding one of the buttons on front plate during powerup :

[T1] for GERMAN

[T2] for ENGLISH resp..

[T3] for FRENCH.

The system remembers the selected language on next system start – even through a FACTORY - RESET

(refer ...). Factory default is GERMAN

Factory Reset :

Resetting the units parameters to the factory default settings occurs by pushing and holding the buttons [PRG] und [T3]

Only the language selection will not be affected from this factory reset.

4.1.1 START OF THE INSTALLATION-RUN

To initialize the system, an installation-run has to take place. This installation-run may only be started by authorized technicians which are trained on this system-technology.

After installing and checking all external components, the installation-run will be started as follows :

```
XXXXXXXXX      XXXXXXXXX
SYSTEM_OK      EVA16M
```

after pressing the red button [**PRG**] the SELECTION MENU appears :

```
T1=ERROR      T2=RESET
T3=PROG.      T4=MP3 TEXT
```

after pressing the button [**T3**] the current software version is shown

```
???  PASSWORD  ???
VERS.4.33  v. 07.03.12
```

and you will be asked for a password ...

After typing [**PRG**] [**PRG**] [**PRG**], the PROGRAMMING-Menu appears

```
T1=NEXT      T2= LEVEL
T3=INST.     T4= NF/REL
```

Pressing the button [**T3**] now starts the installation-run ...

In case of EVA 16 S and /or EVALINE units are connected to EVA 16 M by cascade port, their installation run will start automatically with the run on EVA 16 M.

In the following, the connection between EVA 16 M and EVA 16 S/ EVA LINE will be monitored permanently from EVA 16 S / EVA LINE .

This function only can be suppressed by resetting the EVA 16 S / EVA LINE to factory default settings.

4.1.2 DISPLAYING THE IDENTIFIED COMPONENTS

In the following there are some examples of display texts in order of their appearance on the installation run :

Checking for connected alarm-lines :

```
ALARM 1    3,3 V
INSTALLED
```

(example: only one alarm button;
the covered button: ALARM 1, on the frontpanel)

```
ALARM 2    5,0 V
NOT INSTALLED
```

(not present)

```
ALARM 3,   5,1 V
NOT INSTALLED
```

(not present)

```
ALARM 4    5,0 V
NOT INSTALLED
```

(not present)

Searching for microphone terminal on the SYS-bus (ex.: 2 term. on addr. 1 u.3)

```
EVA TER 80
13
```

Functional check of amplifier lines / outputs
and checking for allocated output - lines

```
OUT:  1
LINE   1,2,3
```

(here: „amp“ means sum output
1..4)

(there may be 1, two or three
amplifiers)

```
OUT:  2
LINE   4
```

```
OUT:  3
LINE   5,6
```

```
OUT:  4
LINE   7,8
```

Searching for a spare amp

```
SPARE AMP:
INSTALLED
```

(here: successful)

Checking the speaker lines:

```
LINE 1:  
A: 15WATT B: 25WATT
```

```
LINE 2:  
A: 64WATT B: 28WATT
```

...

```
LINE 8:  
A: 00WATT B: 17WATT
```

(.. no speaker on the A-line)

Checking the voltage of the battery of the emergency power supply

```
BATTERY:  
27 V INSTALLED
```

respect. *NOT INSTALLED*
when battery power is not present

Checking the for fire-mics

```
FIRE MIK1 3,3V  
INSTALLED
```

(f.e.: the hand held microphone
EVA 16 SYS FH (... TER FH)

```
FIREMIK1 CAPSULE:35  
INSTALLED
```

3,3 V represents the voltage at
the request-contact

The 2nd value monitors the
dynamic mic capsule

```
FIRE MIK1 5,0V  
NOT INSTALLED
```

```
FIRE MIK1 CAPSULE 119  
NOT INSTALLED
```

(f.e.: fire-mic port 2 unused)

After a successful execution of the installation run, in display will appear:

```
XXXXXXXXX XXXXXXXXXXXXX  
SYSTEM:OK EVA16M
```

(respective „S“ for a slave-unit)

During the installation-run, the installer has to take care that all the relevant components were identified with reasonable values of parameters.

Otherwise, not identified alarm-lines and components will not work afterwards.

Selecting audio sources causes the appearance of text-messages in the display of the master unit: This is not affected of the appearance of any fault messages; so, the use of the respective audio-source causes the listed message :

```
02 CHIME      124
XXXXXXXXXX XXXXXXXXXXXX
```

chime on output sum 1,2 and 4

(*nnnn* stands for activated sum-outputs)

```
03 ALARM 1   nnnn
XXXXXXXXXX XXXXXXXXXXXX
```

```
04 ALARM 2   nnnn
XXXXXXXXXX XXXXXXXXXXXX
```

```
05 ALARM 3   nnnn
XXXXXXXXXX XXXXXXXXXXXX
```

```
06 ALARM 4   nnnn
XXXXXXXXXX XXXXXXXXXXXX
```

```
07 TEXT 1    1234
XXXXXXXXXX XXXXXXXXXXXX
```

(the MP3-file on memory 7 will be routed to the audio-sums 1,2,3,4)

```
08 TEXT 2    1 4
XXXXXXXXXX XXXXXXXXXXXX
```

(the MP3-file on memory 8 will be routed to the audio-sums 1,4)

concerning microphone-terminals

terminal type

```
SYS 4/2      nnnn
XXXXXXXXXX XXXXXXXXXXXX
```

EVA16 SYS 2 or EVA16 SYS 4

```
SYS 8        nnnn
XXXXXXXXXX XXXXXXXXXXXX
```

EVA16 SYS 8

```
SYS80       nnnn
XXXXXXXXXX XXXXXXXXXXXX
```

EVA16 SYS 80

```
TER         nnnn
XXXXXXXXXX XXXXXXXXXXXX
```

EVA16 TER

```
SYSFH       nnnn
XXXXXXXXXX XXXXXXXXXXXX
```

EVA 16 SYS FH handheld type

```
SYSFT       nnnn
XXXXXXXXXX XXXXXXXXXXXX
```

EVA 16 SYS FT desktop type

A request on an AUX – Input will cause a display text similar to the following :

AUX 1
ZONE 12 3

(the audio signal connected to
AUX 1 will be routed to the output
sum 1 and 2
relay 3 is activated [opened !])

AUX 2
ZONE 234 8

(the audio signal connected to
AUX 2 will be routed to the output
sum 2,3 and 4 ,
relay 8 is activated [opened !])

NOTICE: please consider, that the programming of the relays works on
i n v e r t e d logic; that means: lines, that should not be affected of a call have
to be switched off by a programmed / working relay

EVA LINE :

Practicable display texts during the installation run in the order of their
appearance

As on EVA16 , but reduced to the topics :

- Output-Assignment OUT 1 – Kreis nnn
- Output-Assignment OUT 2 – Kreis nnn

- Presence of a spare amplifier :

- Checking the output-lines 1 - 8

- Checking the output voltage of the battery power supply :

After a successful installation run the display shows :

EVALINE
SYSTEM: OK

Just as on EVA 16 M/S, the installer of the system has to initialize this
installation run mandatory !
During the installation run, the installer has to take care, that the system
recognizes all relevant components.

4.2 MUSIC: LEVEL AND ROUTING OF ENABLED SOURCES

Setting levels :

Starting at the following display :

Zone 1	music n
SYSTEM_OK	EVA16M

[T1] .. [T4] Pressing one of these buttons selects the audio sum to be edited. Every additional push steps the selection to the next available input working to the actual output.

For music playback there can be enabled by programming an arbitrary selection of the four music inputs.

Sources may be disabled for different zones

example: *music 1 / music 4* / => and again *music 1* ;
the inputs 2 / 3 were disabled and can't be selected

By pushing the button [VOL] the display changes to

LEVEL – Menu

OUT 1	music 1
LEVEL: music 3	-12dB

[VOL] (multiple) pressing of the button [VOL] selects one of the listed input sources for adjusting the audio level going to the actual output:

music 1 => music 2 => music 3 => music 4 => music-master => GONG =>
TEXT 1 => TEXT 2 => AUX 1 => AUX 2 => and returning to music 1

[+] and [-] buttons set the level for the displayed combination of input-source and output sum/zone

+ : raises the level

- : decreases the level

valid values are :

- music 1..4, chime (GONG),text 1..2 und AUX 1..2 : -16dB" ... "-00dB"

- music master: "-30dB" ... "-00dB"

If “ - dB ” appears as a level value, this input source is disabled for the actual output sum

(also refer to Chapter „Installation“)

4.3 ERROR – MESSAGES AT THE SYSTEM EVA16 :

EVA16 M/S / EVA Line announce internal or external errors at the system unit by

- sounding buzzer
- blinking a red error-LED on the front side
- switching the corresponding error relay
(transferring the error message to a central control room...)
- showing the following error-messages in the display of the central unit:

```
XXXXXXXXXX      XXXXXXXXXXXX
SYSTEM_ERROR    EVA16M
```

at external microphone-terminals EVA 16 TER or external FirePanel

- by blinking of an error-LED and
- by sounding of a buzzer

The buzzer of the central unit can be turned off as follows:

After pressing the red button [**PRG**] the following SELECT - Menu appears

```
T1=ERROR      T2=RESET
T3=PROG.      T4=MP3 TEXT
```

 (T4=MP3 TEXT in display only at EVA 16)

And after pressing the button [**T2**] the following RESET – Menu appears :

```
T1= SIREN OFF
T2= LINE RELAYS
```

ATTENTION: By pressing button [**T1**] the buzzer will be blocked permanently; it's not possible to reactivate it for this actual error !

To indicate an other, newly appeared error, the buzzer will work normally.

After termination of an actual error, the listed message will be moved to the list "old errors" and the display will be cleared to a standard view.

The system now works as fixed in installation run.

NON SELFRECOVERING ERRORS : After determining a short line on a speaker line, the corresponding relay will separate the line from the system. The line will not be re-connected to the system automatically, even when the line error is removed. This line has to be reconnected by an active reset as follows :

After pressing the red button [**PRG**] the following SELECT-Menu appears:

```
T1=ERROR      T2=RESET
T3=PROG.      T4=MP3 TEXT
```

... and after pressing button [**T2**] the RESET - Menu comes up :

```
T1= SIREN OFF
T2= LINE RELAYS
```

By pressing the button [**T2**], all separated line relays will be reactivated.

In the same way the activation of a spare amplifier has to be reset; using the same keystroke sequence, the system will be set to standard mode.

If an error message appears in system EVA 16 M/S, you have to inform immediately the installation-company or the technician of the service company, which is assigned to maintain the system !

An exact specification of the error/type can be displayed at the central unit :
by pressing the red button [**PRG**], the SELECT-Menu appears:

T1=ERROR	T2=RESET
T3=PROG.	T4=MP3 TEXT

and after pressing button [**T1**], the following displayed ERROR -Menu :

T1= ACTUAL ERROR
T2= PREV. ERROR

ACTUAL ERROR (AKTUELLE FEHLER): After pressing button [**T1**] eventually present error(s) will be listed in the display

If there is more than one error at the same time, so the corresponding error texts will be displayed sequentially;

10 seconds after completing the ACTUAL ERROR list, the display changes to standard view. This happens immediately if there is no actual error.

Displaying the actual errors can be repeated as often as required.

PREVIOUS ERRORS: after pressing the button [**T2**] previous error messages will be listed in display.

If there is more than one error to be listed, the corresponding error texts will be displayed sequentially;

10 seconds after completing the PREVIOUS ERROR list, the display changes to standard view. This happens immediately if there is no previous error.

Displaying the former errors can be repeated as often as required.

[The FORMER ERRORS - list only can be cleared by a complete installation run.]

List of Error – messages:

In display may appear as described in the following :

Display/message : Description

1) Speaker lines :

SHORT LINE

A speaker line has a short line.

Speakers, which are connected to this line probably will not work.

=> serious problem

BROKEN LINE

a speakerline is broken

speakers, which are connected behind the concerned position may not work properly .

=> serious problem

IMPEDANCE

A speaker line is affected by a change in the impedance; some of the connected speakers in this line may work not properly

In an A/B wired system, one of the lines may be broken

=> may cause a serious problem

GROUND

A speakerline announces a ground fault;

some of the connected speakers in this line may work not properly

=> may cause a serious problem

2) Power amplifier

AMP DEFEKT

A poweramp does not work properly.

If there's no spare amp, some speaker lines may not work properly

=> may cause a serious problem

SPARE AMP

the spare amp does not work properly

In a Voice Alarm System with no background music, this does not affect the functionality of the system for the moment; it's not really a serious problem as long as all the other amplifiers still work properly. All announcements and alarm tones can be heard !

During announcements – depending on the configuration - the internal measurement functions will be blocked.

If now a standard amplifier fails, some of the connected speakerlines may work not properly.

=> may cause a serious problem

It may take 40 ... 75 sec. to detect such an effect.

3.) Fire – mic(s)

(EVA 16 only)

**FIRE MIC 1
REQUEST**

The request-line to control the routing of the micro line “fire mic 1” is shortened or broken; this causes the malfunction of the fire-mic connected to fire-mic-line 1

=> serious problem

**FIRE MIK1
CAPSULE**

The mic capsule on mic line „fire mic 1“ or its wiring is damaged. In case of an alarm, the fire-mic does not work properly or even doesn't work at all.

=> serious problem

**FIRE MIC 2
REQUEST**

And

**FIRE MIK 2
CAPSULE**

similar to fire-mic 1 , but now for fire-mic 2

It will take 20 ... 40sec. to detect a capsule problem.

It will take about 5sec. to detect a request problem .

4.) Desktop terminal error (EVA 16 M/S)

EVA TER 80 1

The permanently supervised terminal EVA 16 TER 80 or EVA SYS 80 with address 1 is damaged ...
(capsule or/and request)

It may take 40 ... 75 sec. to detect such an effect.

Alarm lines

**ALARM 1
REQUEST**

the request line to control the start of the alarm signal
ALARM 1 is broken or shortened

in case of emergency the text or the alarm-signal can

=>serious problem

**ALARM 2
REQUEST**

**ALARM 3
REQUEST**

or

**ALARM 4
REQUEST**

or

similar to ALARM 1 , but now for the corresponding
alarm lines ALARM 2 / 3 / 4.

It will take about 5 to 15 sec. to detect such a problem .

6.) Voice memory

**MP3 TEXT
ERROR**

The internal audio-memory to reproduce audio or text-
messages does not work properly.

The stored audio signals and signal tones can not be
replayed in case of emergency.

=> serious problem

It will take about 5 to 15 sec. to detect such a problem .

7) Main Power failure

POWER FAIL

The central unit is not fed by 230V.

The internal fuse is blown or the external Mains supply
fails.

If there is a working battery-backup-system, the unit works for a limited time.
Depending on battery capacity, battery age, preceding events and charging state,
the system will break down soon if main power doesn't return.
Even when main power returns, it will take certain time to recharge the batteries
completely.

The absence of mains power causes (when battery voltage is present) an error
– notice, followed by the audio mute of the 4 audio inputs music 1 .. 4 and a
low-cut function on all outputs of the system to reduce the consumption of battery
power .

=> serious problem

The problem is announced instantly.

8) Battery Voltage

BATTERY VOLTAGE

The voltage of the 24V backup-battery drops below 20V. On presence of mains-voltage, the system works properly . An additional main power breakdown causes the total breakdown of the system.

=> serious problem

The problem is announced instantly.

Exclusively on master/slave systems on slave system can appear the following message :

9) Bus-connection broken

CAT5 - CONNECTION

the connection to the EVA 16 M (Master) is broken. Probably the slave-system works correct as local a stand-alone-system; external alarm start or announcements can no longer be triggered from master

=> serious problem

It may take 40 ... 75 sec. to detect such an effect.

5. PROGRAMMING

5.1 LEVEL AND ROUTING / DISABLING AND ENABLING OF AUDIO-SOURCES :

This is an example for a standard display view of a EVA 16 M/S :

```
zone 1          music 1
SYSTEM_OK      EVA16M
```

To reach the PROGRAMMING-Mode, behave as follows :

After pressing the red button [**PRG**], the SELECTION – Menu appears :

```
T1=ERROR      T2=RESET
T3=PROG.      T4=MP3 TEXT
```

After pressing the button [**T3**] (= PROG.), the firmware-version is displayed

```
??? password  ???
V 4.33       10.03.12
```

and you will be asked for the password

After typing the requested password word, “[**PRG**][**PRG**][**PRG**]” the system reaches the PROGRAMMING -Menu

```
T1=NEXT      T2=PEGEL
T3=INST.     T4= NF/REL
```

By pushing the button [**T2**] you will reach SOURCE-Config Menu

```
Zone 1          music 1
LEVEL: music 3  -12dB
```

In principle, this includes the identically basic functions like the LEVEL-Menu (USER), which can be reached directly by pressing the button [**VOL**]

It displays

- the selected output sum/zone {zone_1},
- the corresponding audio source {music_1}, and
- the actual selected source { music_3 } with their level to edit

(+ / - buttons for leveling, monitors the actual level in dB)

The following levels can be edited here:

music 1 / music 2 / music 3 / music 4 / music master / chime(GONG) /
TEXT 1 / TEXT 2 / AUX 1 / AUX 2 / master volume / TREBLE / BASS /
SYS 4/2 (TER 4/2), (microphone) / EVA 16 SYS 8/80, EVA 16 TER (EVA
TER8/80/PRO) (microphone) / ALARM -1 / ALARM -2 / ALARM -3 /
ALARM - 4 / FIRE-MIC 1 &.2 / => and back again to music 1

Setting the volume :

[+]: increases the volume [-]: decreases the volume

Reasonable values:

- at music 1 .. 4,
GONG,
Text 1..2,
AUX 1..2,
SYS 4/2 (TER 4/2,)
SYS 8/80, TER (TER 8/80/TER 80 PRO) and
FIRE Mic : "-16dB" ... "-00dB"

routing and blocking/unblocking of sources / relay programming :

For one ore more of the listed sources, level may be shown as " - - dB" ;
this means, that the routing of this source to the actual selected output zone is
blocked by programming.

This sources can not be activated in USER-mode by multiple pressing one of the
output-buttons [T1] [T4]

Level-values for :

music master :	"-30dB" ... "-00dB"
volume :	"-68dB" ... "-00dB"
treble :	"-15 dB" ... "+ 15 dB"
bass :	"-15 dB" ... "+ 15 dB"

Audiorouting :

After pressing the red button [PRG] / [T3] / "[PRG][PRG][PRG]" it
appears like:

T1=NEXT	T2=LEVEL
T3=INST.	T4= NF/REL

After pressing the button [T4] (NF/REL) the system is in the SOURCE-Config
Menu

T1 =TEXT/AUX/ALARM
T2 = TER4/2

After pressing the button [T2] , it will appear

Button-Nr.1	T1=NEXT
T3=AUDIO	T4=RELAIS

This means:

Here is to program the audio routing and the relay function corresponding to
button 1 of a terminal EVA 16 SYS 4/2 (... TER4/2)

[T1] (NEXT) increases the number of the button 01,02, ... 80
which is to edit

After pushing [T3] („audio“), system shows for example in display:

```
T3=SELECT    T4=SET/CLR
I      I      I 2 I 1 I
```

That means : By pressing the button 1 on the microphone desk, the audio signal will be sent to audio output 1 + 2

[T3] (SELECT) and [T4] (SET/CLR) are to edit the programming

5.2 RELAY PROGRAMMING :

After pushing [T4] („relay“), system shows for example in display:

```
T3=SELECT    T4=SET/CLR
I I I6I I4I I I I
```

That means for example:

By pressing the button 1 on the microphone desk, the relay with number 4 and number 6 will open and the 100V speaker signal will be blocked.

[T3] = WAHL and [T4] (SET/CLR) are the buttons to edit the programming

5.3 SPECIAL FUNCTIONS:

Pre-announcement chime :

After pressing the red button [PRG] / [T3] / “[PRG][PRG][PRG]” it appears like:

```
T1=NEXT      T2=LEVEL
T3=INST.     T4= NF/REL
```

(EVA 16 M/S only)

By pressing button [T1] the system reaches the SOURCE - Config Menu

```
T2= CHIME ON  T1= NEXT
```

Here is to decide, whether a chime (gong) is to be heard before microphone opens for an announcement from EVA 16 SYS 4/2 ,SYS8, SYS80, SYS TER or not. Pushing the button [T2] („GONG“) switches this function ON respective OFF

Ground error :

After pressing [T1] the display shows as follows:

```
T2 = GROUND
T1 = NEXT
```

Here is to decide , whether the measurement for ground faults has to take place for all speaker lines, or if some of them may rest disregarded.

It is in the same manner as on the relay programming

```
T3=SELECT    T4=SET/CLR
I8I7I6I5I4I3I2I1I
```

By [PRG] the system returns to the previous menu ... or after 10 seconds without any button activity.

Impedance error :

After pressing [T1] the display shows as follows:

T2=IMPEDANCE T1=NEXT

Here is to decide , whether the measurement for impedance faults has to take place for all speaker lines, or if some of them may rest disregarded.

It is in the same manner as on the relay programming

NOTE: When using 100v-speaker-level-controls, the impedance monitoring has to be switched off. Please note that the use of 100v-speaker-level-controls may reduce the sensitivity of recognition problems on this speaker lines. Always use level-control with bypass relay .

returning the system to the previous menu by pushing [PRG] button... or after 10 seconds without any button activity.

Short circuit error :

After pressing [T1] the display shows as follows:

T2=SHORT CIRC. T1=NEXT

Here is to decide , whether the measurement for short circuit faults has to take place for all speaker lines, or if some of them may rest disregarded.

It is in the same manner as on the relay programming

By [PRG] the system returns to the previous menu ... or after 10 seconds without any button activity.

Broken Line error :

After pressing [T1] the display shows as follows:

T2=BROKEN LINE T1=NEXT

Here is to decide , whether the measurement for broken line faults has to take place for all speaker lines, or if some of them may rest disregarded.

It is in the same manner as on the relay programming

By [PRG] the system returns to the previous menu ... or after 10 seconds without any button activity.

5.4 ALARM-START

After pressing [T1] the display shows as follows:

T2 = ALARMSTART
ALARM 1-4 = ALARM 1-4

The four alarmlines normally work completely independent from another; an alarm on alarmline 1 triggers its own alarm 1 audiofile; alarmlines 2,3,4 act in the same way for the files 2, 3, 4.

NOTE: In this mode there may be more than one request on the different alarm lines, but only the one with the highest priority will be performed exclusively in its audio- and routing functions !

Pushing [T2] initiates the following display content :

```
T2 = ALARMSTART
ALL LINES = ALARM 1
```

Any alarm signal on the lines 1..4 now triggers the Alarm 1 audio-file together with it's own stored routing

As there is only one single audiofile to play, more than one request may be added (!) to a completely new alarm-scenario

By [PRG] the system returns to the previous menu ... or after 10 seconds without any button activity

5.5 ALARM-CODE-PAGE (ADDITIONAL ONLY ON SLAVE-UNITS !)

After pressing [T1] the display shows the following menue :

```
T2=ALARMCODE T1=NEXT
```

After pressing [T2] the display shows the following alarmcode-menue :

It only serves to configure the alarmsetup slave in a MASTER/SLAVE – System

On default, all alarms work on slave systems like on the master unit. When MASTER requests ALARM 2, then SLAVE requests ALARM 2 in the same manner. - This may be changed here:

```
T3=SELECT T4=SET/CLR
|x|x|6|5|4|3|2|1|
```

Default-setting of ALARMCODE

The meaning of the numbers are listed in the following:

- 6: Alarm 4
- 5: Alarm 3
- 4: Alarm 2
- 3: Alarm 1
- 2: Text 1
- 1: Text 2

if positions are set completely as shown all the functions of the master unit Alarm 1..4 and Text 1, 2 will be transmitted in the same way from master to slave system !

(pos. 7 u. 8 provide no function at the moment)

```
T3=SELECT T4=SET/CLR
|x|x|6|5|4| |2| |
```

Programmed like this, ALARM 1 or TEXT 1 would not start on SLAVE when ALARM1 / Text 1 are started on Master.

5.6 IMPEDANCE TOLERANCE :

After pressing [T1] the display shows as follows:

```
T2 = IMP. TOLERANCE
NORMAL (07)
```

```
T2 = IMP. TOLERANCE
HIGH (22)
```

```
T2 = IMP. TOLERANCE
SMALL (04)
```

at the moment the impedance selectivity of the system is at standard level

By multiple pushing [T2] you can set the tolerance SMALL (04), NORMAL (07) or HIGH (22)

By pushing [PRG] the system returns to the previous menu ... or after 10 seconds without any button activity.

5.7 LEVEL OF PILOT SIGNAL :

After pressing [T1] = NEXT the display shows as follows:

```
T2 = +   T3 = -   30 V
                T1 = NEXT
```

Using the buttons [T2] = + or [T3] = - the level of the pilot can be adjusted from 20Vpp to 60Vpp. Default level is 49Vpp.

Changes should only be made by authorized technicians.

After changing the pilot level, all the measurement-values will change and an installation-run has to take place; else you will have error signal after a few seconds ...

By [PRG] the system returns to the previous menu ... or after 10 seconds without any button activity.

5.8 MEASUREMENT (MESSUNG) :

After pressing [T1] the display shows as follows:

```
MEASUREMENT / MESSUNG
T1 = NEXT   T2 = START
```

Pushing the START Button [T2] suppresses all internal system-measurements, so external measurement processes (StiPa ...) will not be affected or even falsified. The audio input AUX 2 will be routed to all audio output-sums. ALARM 2 stays triggerable.

```
MEASUREMENT      1 2 3 4
RED BUTTON:      STOP
```

ATTENTION: While the system remains in this state, all other functions (like alarming, speaker or amp-monitoring) are switched off until the system will be restarted by pressing the red [PRG] button.

5.9 POWER – ON – RESET :

The unit's parameters can be set to factory – default.

CAUTION: All programmed values and parameters (level / routing / ...) will be cleared and set to factory default.

Please save your parameters eventually by downloading the settings using the software EVA Mon © (ref. chapter 6.2)

To reset the unit to factory defaults handle as follows :

Turn off the power supply of EVA 16 M/S (switch off 230 V and remove the 24 V –plug)

Press and hold the buttons **[PRG]** and **[T3]**

During you hold the buttons down turn ON the power supply voltage again.

First appears for a short moment...

FACTORY RESET

After 5 sec. the system comes up in the standard way,

zone 1 music 1
SYSTEM_OK EVA16M

resp.

EVALINE
SYSTEM:_OK

but with all parameters reset.

Don not forget to reconnect all removed power supply voltages (230V / 24V) ...

6. CONNECTING A PC

6.1 USING WINDOWS XP © HYPERTERMINAL

Connect EVA 16 M / S for example to the port COM1 of your PC using a crossed 9pin serial cable (null-modem cable). Start your communication program, - WINDOWS © Hyperterminal for example - and set the communication parameters as follows :

baud rate	bits/sec	9600
databits		8
parity		none
stopbits		1
protocol		none

Pressing the button > i < („information“) on the PC-keyboard causes the following view: (for EVA Line without 2 and 5)

TKEY ALLOCATION EVA 16 M/S / EVA Line

```
KEY 1 : installed components
KEY 2 : Audio level
KEY 3 : Audio and relayprogramming
KEY 4 : Misc. setting
KEY 5 : Text input
KEY 6 : Errors
KEY 7 : Factory setting
Caution !! Deletes all settings
```

Pressing the number-button >1< to >7< on PC-keyboard causes the following view:

Taste > 1 < :

button > 1 <

INSTALLED COMPONENTS

■	ALARM 1	3,3V				(3,3V = o.k.)
■	ALARM 2	3,3V				(3,3V = o.k.)
■	ALARM 3	3,3V				(3,3V = o.k.)
■	ALARM 4	3,3V				(3,3V = o.k.)
■	FIRE MIK1	3,3V	COIL:INSTALLED			(installed)
■	FIRE MIK2	3,3V	COIL:INSTALLED			(installed)
■	EVATER80	13			(addr. 1 and 3 present)	
■	OUT:1	LINE: 1 036	A: 14 Watt	B: 28 Watt	Pilot	00dB
■		LINE: 2 032	A: 12 Watt	B: 25 Watt	Pilot	00dB
■	OUT:2	LINE: 3 036	A: 14 Watt	B: 28 Watt	Pilot	00dB
■		LINE: 4 021	A: 12 Watt	B: 15 Watt	Pilot	00dB
■		LINE: 5 036	A: 14 Watt	B: 28 Watt	Pilot	00dB
■		LINE: 6 036	A: 14 Watt	B: 28 Watt	Pilot	00dB
■	OUT:3	LINE: 7 082	A: 52 Watt	B: 31 Watt	Pilot	00dB
■	OUT:4	LINE: 8 036	A: 14 Watt	B: 28 Watt	Pilot	00dB
■	SPARE AMP	INSTALLED				(installed)
■	BATTERY VOLTAGE	27V				(installed)
■						

LEVEL	SOURCE	LINE1	LINE2	LINE3	LINE4
a	MUSIC 1	-07 dB	-12 dB	-- dB	-- dB
b	MUSIC 2	-05 dB	-05 dB	-- dB	-13 dB
c	MUSIC 3	-- dB	-- dB	-12 dB	-- dB
d	MUSIC 4	-16 dB	-- dB	-- dB	-05 dB
e	MUSIC MA	-00 dB	-00 dB	-10 dB	-00 dB
f	CHIME	-12 dB	-10 dB	-06 dB	-06 dB
g	MESSAGE1	-04 dB	-04 dB	-06 dB	-05 dB
h	MESSAGE2	-06 dB	-06 dB	-06 dB	-06 dB
i	AUX 1	-06 dB	-06 dB	-06 dB	-06 dB
j	AUX 2	-06 dB	-06 dB	-06 dB	-06 dB
k	VOLUME	-10 dB	-10 dB	-10 dB	-10 dB
l	BASS	00 dB	00 dB	-02 dB	00 dB
m	TREBLE	00 dB	00 dB	00 dB	00 dB
n	SYS 4/2	-03 dB	-03 dB	-03 dB	-03 dB
o	SYSTER80	-00 dB	-06 dB	-06 dB	-06 dB
p	ALARM 1	-00 dB	-- dB	-- dB	-- dB
q	ALARM 2	-09 dB	-06 dB	-06 dB	-06 dB
r	ALARM 3	-01 dB	-06 dB	-06 dB	-06 dB
s	ALARM 4	-06 dB	-06 dB	-06 dB	-06 dB
t	FIRE MIC	-10 dB	-10 dB	-10 dB	-10 dB

To select a value to change :

Type the character in front of the affected line

The complete line will appear in the editor again;

the cursor appears on first position of the line

Change values by [+] and [-] buttons

Select other parameter by pushing -->| respect. [Tab]

To return press [ENTER]

Push 3 to get the listing of subpages 0 ... 4;

then pushing 0 (f.e.) brings the complete list of TER 4/2 and SA(allcall) and first 20 functional buttons of a EVA 16 SYS 80 or a TER

```
[0=SYS TER1-20] [1=TER21-40] [2=TER41-60] [3=TER61-80] [4=ALARM/TEXT/AUX/FIRE]
```

QUELLE	Z1	Z2	Z3	Z4	R1	R2	R3	R4	R5	R6	R7	R8
a SYS 4/2 01	**											
b SYS 4/2 02		**										
c SYS 4/2 03			**									
d SYS 4/2 04				**								
e SYSTER80 SA	**	**	**	**								
f SYSTER80 01	**											
g SYSTER80 02		**										
h SYSTER80 03			**									
i SYSTER80 04				**								
j SYSTER80 05												
k SYSTER80 06												
l SYSTER80 07												
m SYSTER80 08												
n SYSTER80 09												
o SYSTER80 10												
p SYSTER80 11												
q SYSTER80 12												
r SYSTER80 13												
s SYSTER80 14												
t SYSTER80 15												
u SYSTER80 16												
v SYSTER80 17												
w SYSTER80 18												
x SYSTER80 19												
y SYSTER80 20												

To select a value to change :

Type the character in front of the affected line

The complete line will appear in the editor again;

the cursor appears on first position of the line

Change values by [+] and [-] buttons

Select other parameter by pushing -->| respect. [Tab]

To return press [ENTER]

The presentation for the buttons

1 = 21..40,

2 = 41..60,

3 = 61..80 und

4 = ALARM-TEXT-AUX-FIRE

will be in the similar way

TASTE > 4 < : SONSTIGE

(button > 4 < : other settings)

After pushing „4“ the following content appears,

```
a GONG                EIN
b F. GONG             AUS
c MUSIK              EIN
d ERDSCHLUSS         KREIS: 8 ** 7 ** 6 ** 5 ** 4 ** 3 ** 2 ** 1 **
e IMPEDANZ           KREIS: 8 ** 7 ** 6 ** 5 ** 4 ** 3 ** 2 ** 1 **
f KURZSCHLUSS        KREIS: 8 ** 7 ** 6 ** 5 ** 4 ** 3 ** 2 ** 1 **
g UNTERBRECHUNG      KREIS: 8 ** 7 ** 6 ** 5 ** 4 ** 3 ** 2 ** 1 **
h ALARMSTART         MELDER1-4 = ALARM1-4
i IMP. TOLERANZ      NORMAL (7)
j PILOT LEVEL        051 V
k AUTO ERROR OUTPUT  AUS
e IMPEDANZ           KREIS: 8 ** 7 ** 6 ** 5 ** 4 ** 3 ** 2 ** 1 **
```

Typing „e“ f.e. : the complete line for IMPEDANCE will appear in the editor again;

The cursor appears on first position of the line

Change values by [+] and [-] buttons 1

Select other parameter by pushing -->| respect. [Tab]

To return press [ENTER]

TASTE > 5 <: Texteingabe

Text	Eingabe
Zone 1	Taste 1
Zone 2	Taste 2
Zone 3	Taste 3
Zone 4	Taste 4

After pressing button > 1 < on the keyboard, you can edit the text of the zone 1.

type new title on keyboard (max. 12 characters)

To edit text 2

pushing button > 2 <

type new title on keyboard (max. 12 characters)

confirm by pressing >RETURN<

a.s.o.

button > 6 < realtime message output

```
LINE : 1 063 000 000 OK
LINE : 2 032 000 000 OK
LINE : 3 036 000 000 OK
LINE : 4 021 000 000 OK
LINE : 5 036 000 000 OK
LINE : 6 036 000 000 OK
LINE : 7 082 000 000 OK
LINE : 8 036 000 000 OK
FIRE MIC1 REQUEST OK COIL : OK
REQUEST ALARM 1 OK
REQUEST ALARM 2 OK
REQUEST ALARM 3 OK
REQUEST ALARM 4 OK
MP3 TEXTE OK
```

Displaying starts by pressing button > 6 <
and can be actualized any 15 sec. by re-pressing > 6 <

Line 1 ... 8 : When all 3 columns are filled, system begins again with the first
For LINE 1 .. 8, there will be a line even there are no speakers detected,
FireMic, alarms, battery voltage and EVA SYS/TER only are shown when present.

AUTO – ERROR – OUTPUT (automatized realtime statusinfo)

If AUTO-ERROR-OUTPUT is set to ON in menu 4,
the system shows some status information every 45 seconds :

020	023	067	088	015	025	026	088
020	022	066	088	017	024	027	088
020	023	066	087	016	025	027	088
020	023	067	088	015	025	026	088
020	022	066	088	017	024	027	088
020	023	066	087	016	025	027	088
...							

**button > 7 <:
restore factory defaults / factory reset**

After pressing button > 7 < and an additional security instance, there will be a system reset and the factory presets will be reloaded.

ATTENTION : All manual programming will be cleared !

Please save your parameters eventually by downloading the settings with EVA Mon ©
(ref. chapter 6.2)

=====

6.2 DOWNLOAD AND UPLOAD OF PARAMETERS USING **EVAMON**

On demand you may receive the communication software EVA Mon © from your local dealer or the manufacturer. Only use the latest version. Using this you may download and save or upload the values of all parameters inside the EVA 16 M/S or EVA Line.

You can start the software by double clicking on `evamon102.exe`

Please refer to the appearing notice:

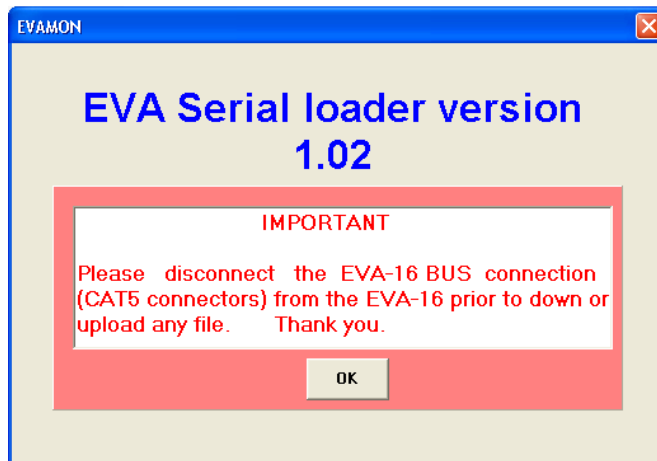

Before starting uploading or downloading any data to or from the system cut all the the RJ45 – connections on the backplane of EVA16

Ignoring this may cause loss of data, error or even complete damage of the system.

After confirming by a click onto [OK] please select the COM –Port:

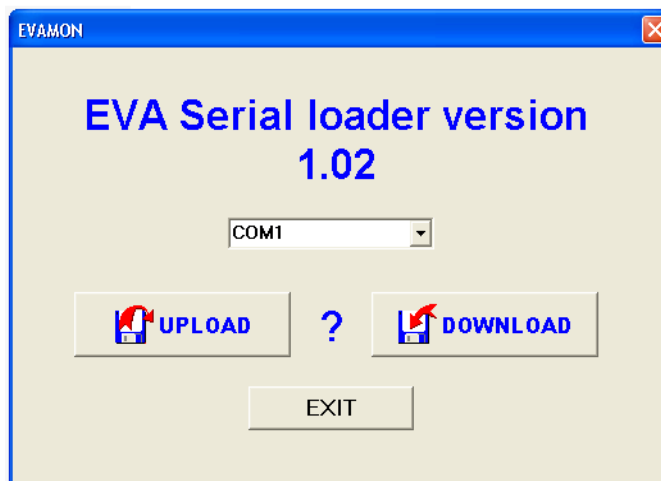

Read Data: press [**Download**] and give a name and a folder to the file *name.evf*

Write Data: press [**Upload**] and select a file *.evf to transfer.

Quit EVAMON by selecting the button [**EXIT**].

Remember to reconnect all the removed RJ45-connectors on the rear side of EVA 16

7. APPENDIX :

7.1 SYSTEM SETUPS (EXAMPLES)

NOTICE when running a master/Slave system :

STANDARD MODE:

In standard master-slave –setup please take care, that speakers which are fed from different EVA16 are not working into the same area - In case of an alarm-call the reproduction of messages with an identical phase - generated from different EVA16-units can not be guaranteed for all situations.

COMMON MODE:

If a phase coupled playout of a message is required, please contact your dealer or the manufacturer to configure the units in that way. The ALARM sound will be taken without exception from the master only; the configuration may be set afterwards, but when doing so you have to make sure, that the correct “dummyfiles” (about 1 sec. longer than the respective files in master unit) have to be stored onto the SD-Cards

When a running ALARM is stopped by pressing the red PRG-button on a EVA 16 M master unit, only alarming in the master unit is stopped, other connected EVA 16 S – systems are not concerned.

When a running ALARM is stopped by pressing the red PRG-button on a EVA 16 S slave unit, only alarming in this slave unit is stopped, other connected EVA 16 M/S – systems are not affected.

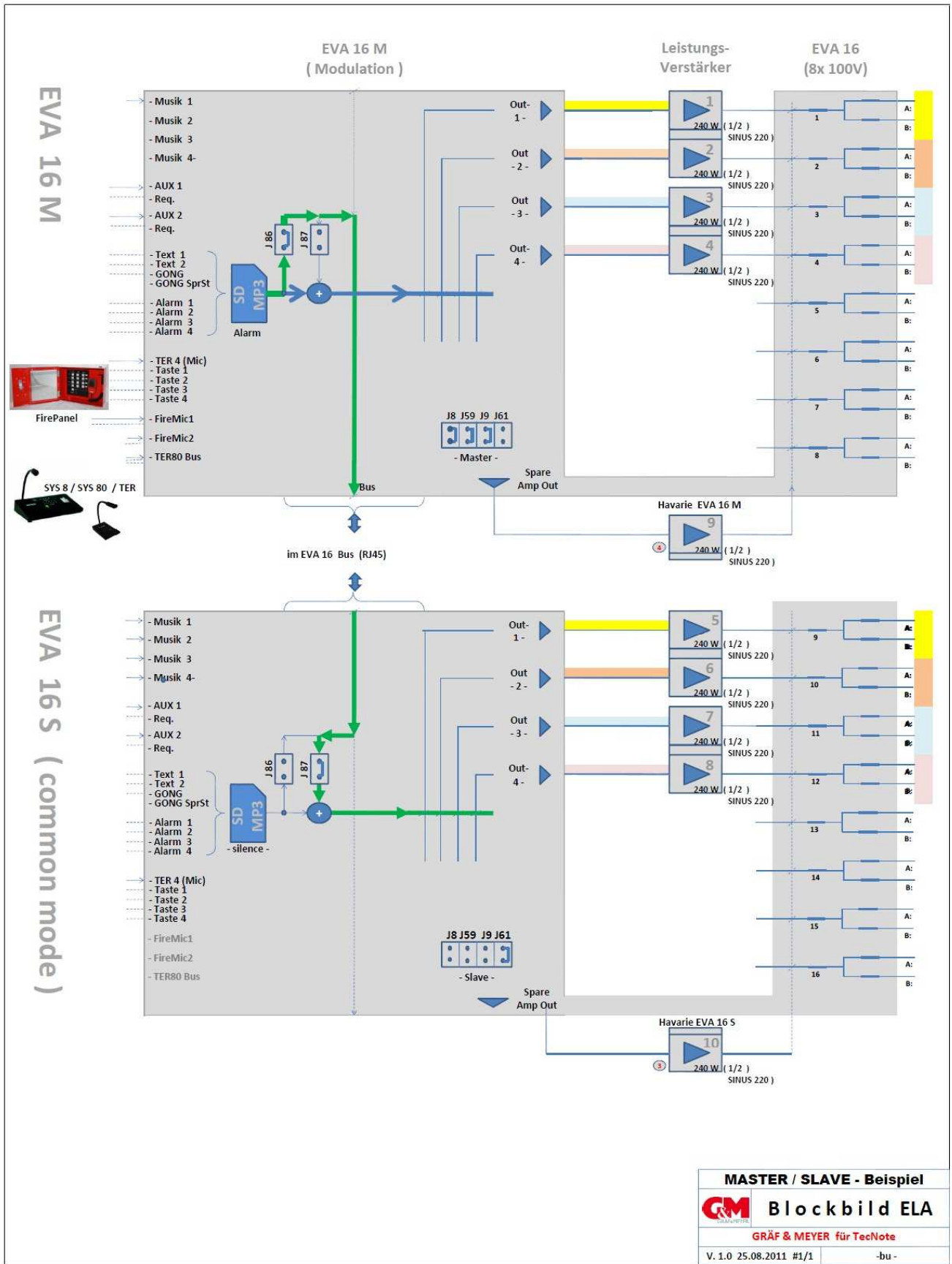

MASTER / SLAVE - Beispiel
CM Blockbild ELA
 GRÄF & MEYER für TecNote
 V. 1.0 25.08.2011 #1/1 -bu-

Jumper	87	86
StandAloneMaster	-	-
Master (mit Slave)	-	x
Slave	x	-

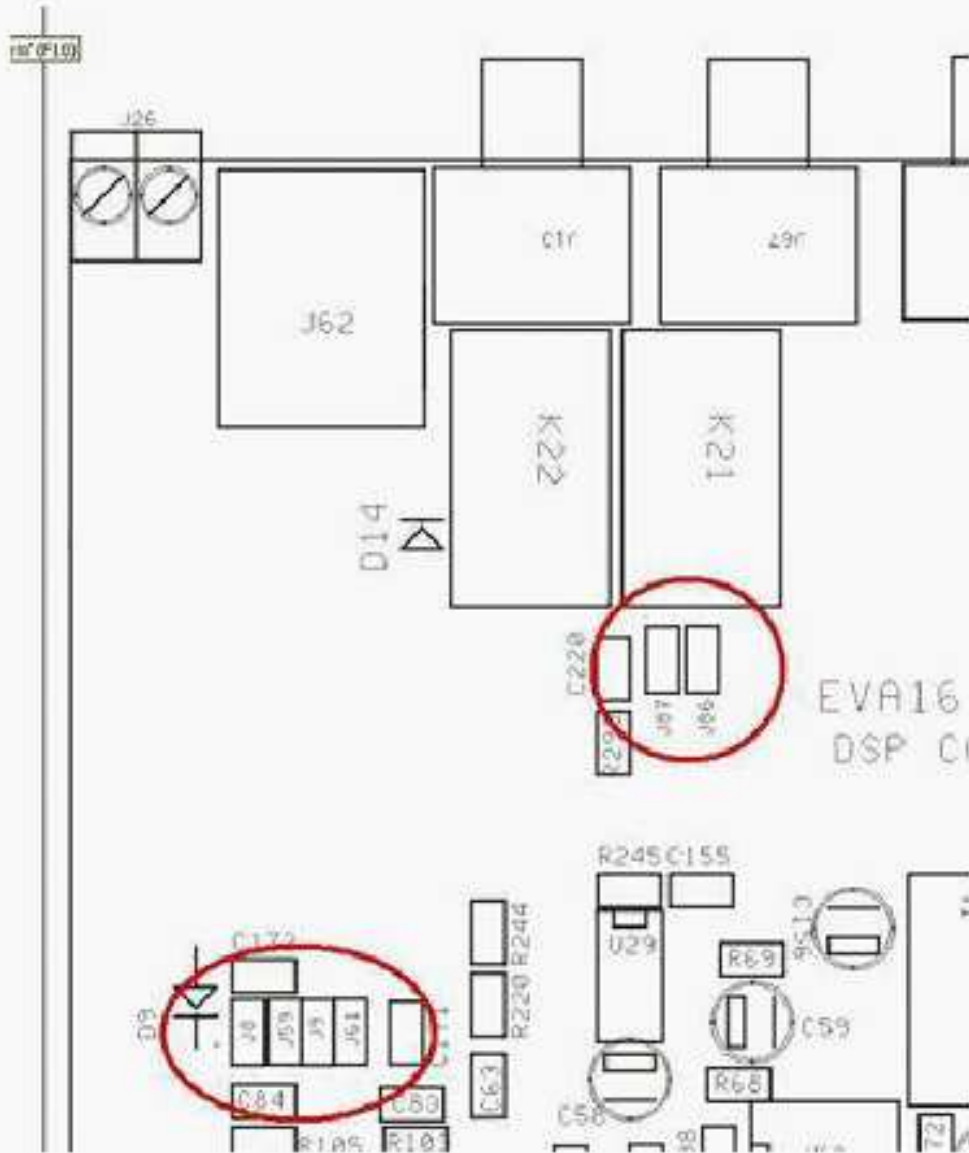

(The position of this shown detail is in the rear, left near the mains connector ...)

For Master Slave use check the following settings

Jumper	8	59	9	61
StandAlone-Master	x	x	x	-
Master (mit Slave)	x	x	x	-
Slave	-	-	-	x

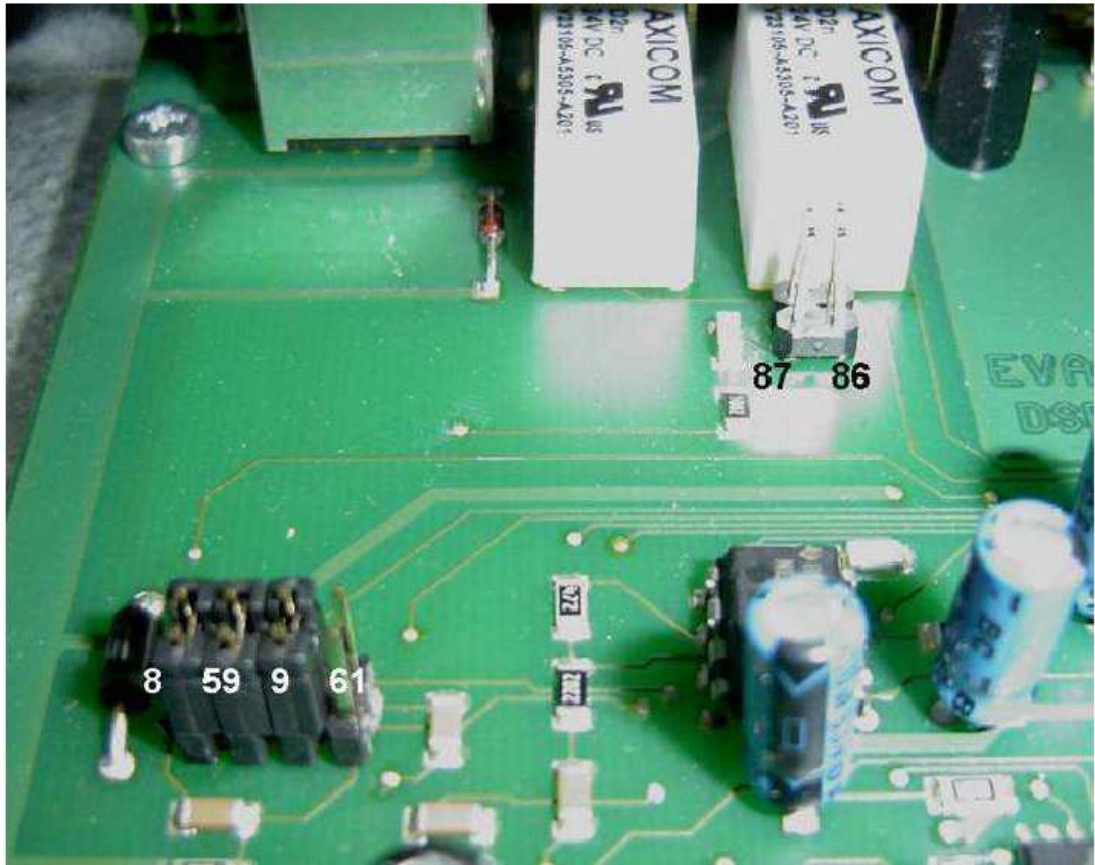

NOTE: When using Master/Slave-Systems in COMMON Mode, on the Slave-SD-card there have to be used dummy files(silence) except the 16kHz testtone. Signals from master an slave will be mixed during the alarm payout.

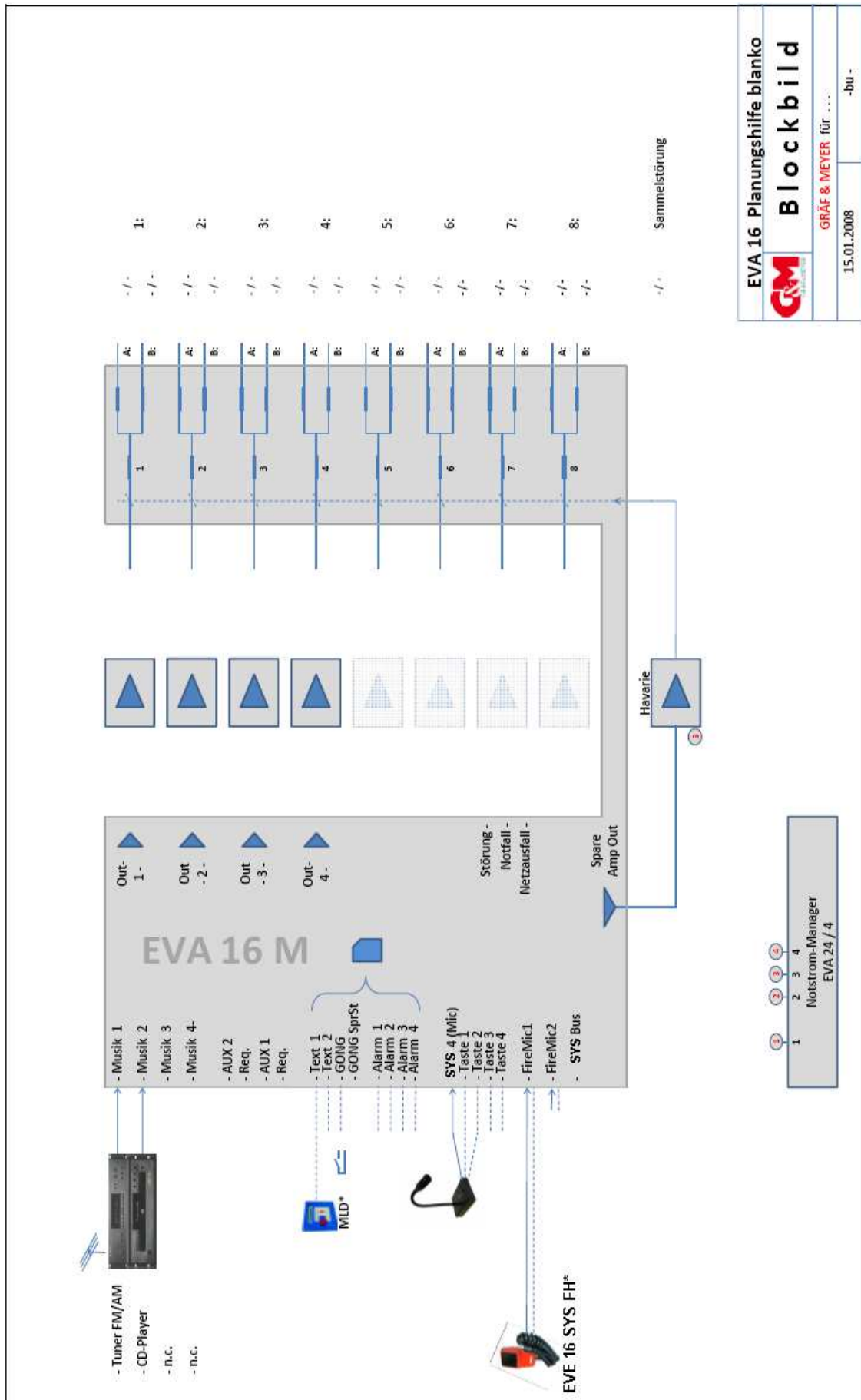

EVA 16 Planungshilfe blanko

GM **Blockbild**

GRÄF & MEYER für ...

15.01.2008

-bu-

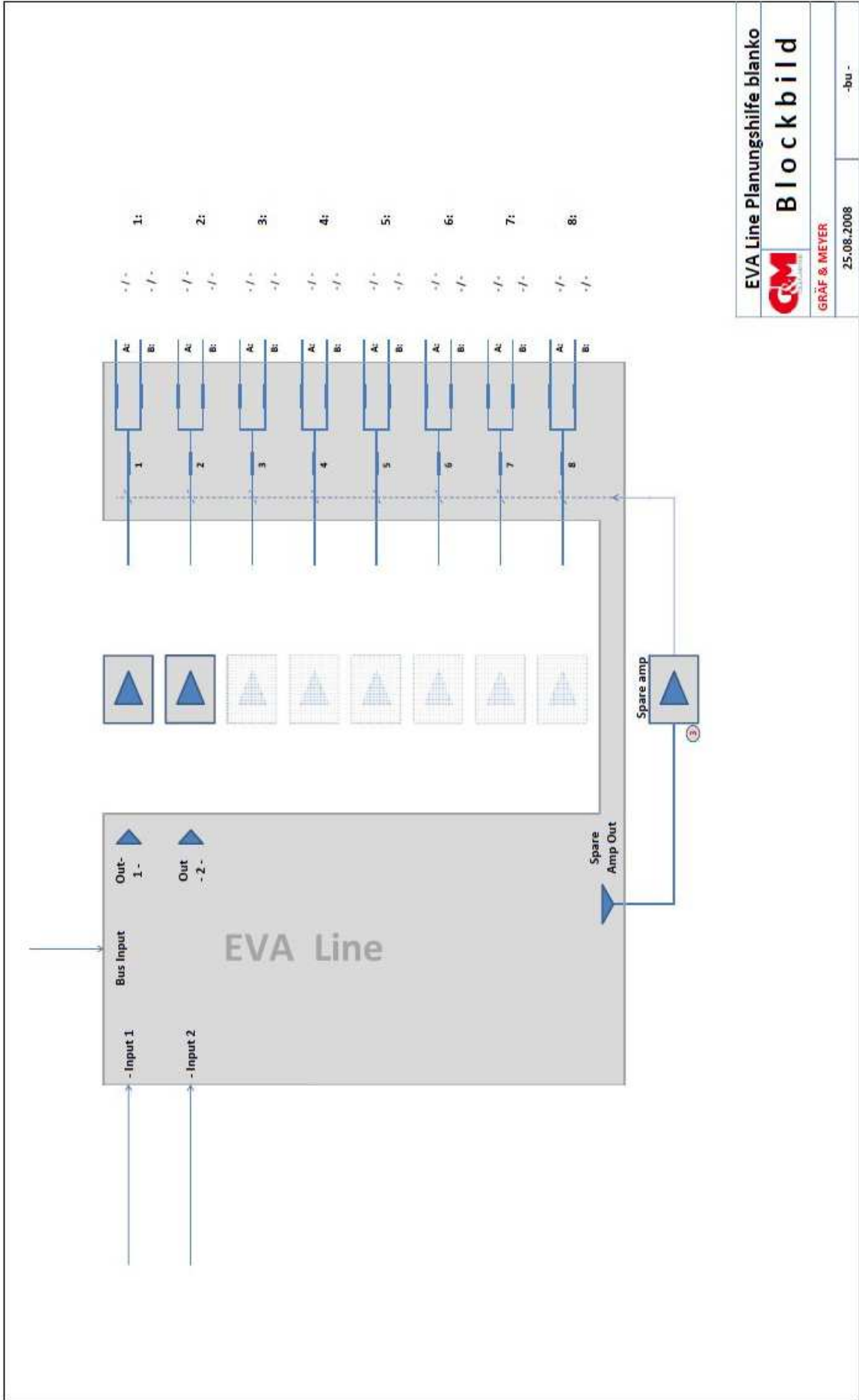

Comparing the units of the EVA 16 family

14.12.2012 -E

-bu-

Eigenschaft	EVA 16 M/S	EVA 8	EVA Line
features			
microphone bus SYS TER, monitore >MIC 80CH Data< (80+10 Funktionen)	RJ 45	-	-
maximum number of terminals SYS 8 / SYS80 / TER	8 monitored, any number of not monitored units *)	-	-
terminal connector SYS 4/2 (4 buttons + audio + gnd + busy)	Phoenix connector (8)	Phoenix connector (8)	-
maximum number of terminals SYS 1 / SYS 2 / SYS 4+1	any number *)	any number *)	-
firemic interface (monitored)	2 (FireMic1: 1x Front Din5pin connector with Renk-lock, 1x Rear on PHOENIX-connector; FireMic2: 1x Rearpanel on PHOENIX-connector)	2 (FireMic1: 1x Front Din5pin connector with Renk-lock, 1x Rear on PHOENIX-connector; FireMic2: 1x Rearpanel on PHOENIX-connector)	-
Music-Inputs Cinch (Line Highlevel)	4	1	-
AUX-Inputs Cinch	2	1	-
Contactinputs for AUX-Request	2	1	-
Contactinputs for Text-Request	2	1	-
Contactinputs for Chime-Request	2	1	-
Alraminputs, monitored	4	2	-
Main inputs Cinch (Line highlevel)	-	-	2
Input connectors for 100V-zone-amplifiers	8	4	8
Input connectors for 100V-spare-amplifiers	1	1	1
Outputs			
Main outputs / programmlines	4	4	2
Main outputs (Line) for spareamp	1	1	1
output connectors for 100V-speakerlines	8 a/b	4 a/b	8 a/b
contacts / status signals	3 x turnover (general fault / mainpower fault / alarm active)	3 x turnover (general fault / mainpower fault / alarm active)	3 x turnover (general fault / mainpower fault / alarm active)

Eigenschaft	EVA 16 M/S	EVA 8	EVA Line
additional interfacing			
RS-232 for controlling and service Purposes	9pol SubD connector / female	9pol SubD connector / female	9pol SubD connector / female
>FUTURE 2< 9pol male SubD-connector for controlling and service Purposes	9pol SubD - Stecker / male (1-6: Firmware / 5-9 ext. Error detect)	-	-
I/O - Port	25pol SubD connector / male	-	-
Data In/Out (I/O-CAS)	1x RJ45 (Slave)	-	1x RJ45 In (+ parallel Out)
Data Output (CAS)	1x RJ45 (Master)	-	1x RJ45 Out (parallel)
ALARM button (covered)	ALARM 1 (Frontpanel)	-	-
Power supply			
230 V - Euro connector	x	x	x
fuse	T2A	T1A	T2A
Power switch 230 V, rearpanel	x	x	x
24 V PHOENIX - connector, 2pin	2pin	2pin	2pin
Housing			
Rackspace	19" - 2U	19" - 1U	19" - 1U
Dimensions	493 x 220 x 89mm	493 x 220 x 44mm	493 x 220 x 44mm
Weight	5 kg	3kg	4 kg

*) theoretcaly: any number, practicaly the number depends on length and kind of cabling

Tips for a clean and error free running of the speaker line-monitoring

Basics :

The units EVA 16 M / EVA Line are designed and developed for a classical A/B – wiring (... the predictions of the actual regulations as for example EN 60849 ...). It is assumed, that the loads for the two output paths (A/B) within a circle in an ideal way are in approximately the same, and that at each output terminal only one outgoing line is present. The reference tone (22kHz) will be fed approx. -16dB_u into the system.

- For reliable results of measurement in each case a measuring paths has to provide a minimal load/power $P_{min} \geq 10 W^*$ ($Z < 1k \Omega$).
- The system generates an error message, if the load of a line (Path A || Path B) determines more than $+20 W^*/- 10 W^*$ (in case of impedance check >NORMALLY<) respective more than $+10 W^*/- 6 W^*$ (in the case of impedance check > SMALL <) from the value stored with the installation run.
To minimize the danger of the occurrence from unfounded (e.g. weather-related) error messages it is recommend to use the operation mode > NORMALLY <

Passive Level control (100V) :

The use of passive level controllers (100V) generally will bring problems. Turning the knob of such a level control will change the impedance of a connected speaker line.

It is necessary that the knob is in its final working position when the installation run starts.

Changes that take place afterwards will cause an error message if they change the total load of the path for more than $+20W/-10W$ (resp. $+10W^*/-6W^*$) .

In the same way, the minimum load for a speaker line - detection depends on the position of the passive-level-control. May be, that a path with a 24W-speaker and a level-control working in $\frac{3}{4}$ position (minus two clics) will not be detected because for the measurement-system there are only 6W visible ($24W -3dB = 12W$; $12W -3dB = 6W$) .

The minimum load to recognize the defect of this line has to be 12W .

So passive level-controllers are not to be used in monitored speaker line-systems

Within the recommendations of the **ZVEI**, an association of manufacturers of voice-alarm-systems, the use of passive speaker level - controllers is strictly rejected for systems that have to correspond to the actual security standards.

Notice : All listed values correspond to the behavior of speakers, transformers and level - controllers at a frequency of 22 kHz. technical data of a speaker at 22kHz can vary from the value at 1kHz enormous, may be four times; so the visible load is only a quarter.

Please think about this facts when planning your speaker monitoring system !

7.4 TECHNICAL DATA

EVA 16 M/S

- audio-inputs: 4, music 0dB unbalanced
2, line source 0dB unbalanced
2, fire microphone, transf. balanced, supervised
2, microphone bus
(EVA16 TER 80 PRO / EVA TER 80/8
resp. EVA 16 TER 4/2)
- audio-outputs 5, 0dB (max. + 10dB) transformer-balanced
- test tone-frequency line 22 KHz and 1kHz (faded, not permanent)
- test tone-frequency fire mic. 1 KHz

- 100V-switching relay 8 max. Voltage. 160V AC
max. switching current.4A AC
(Pmax. 800W/100V)
- other relay contacts max. 120V AC max. 2A AC
- display LCD with 2-lines of 20 character
- audio-memory SD-Card (up to 16GB), *.mp3

- line voltage 230VAC, 50 60 Hz
- fuse; 5x20mm 3,15A slow blow
- emergency DC-power 24V max. 600mA
- temperature range $-5^{\circ}\text{C} < T < 55^{\circ}\text{C}$
- power consumption max. 25 VA
- Housing 19", 1 U (depth: 300mm, without connectors)
Steel-sheet, black

- weight 4,5 kg

- Security information: Do not expose the amplifier to rain or the
environment where it may be splashed by water
or other liquids, for doing so, it may cause fire or
electric shock. The power plug is for
disconnecting the unit from main power, keep the
plug reachable. Only use on main plug with
protection earth pin present.

EVA Line

- audio-inputs: 2, line source 0dB unbalanced
 - audio-outputs 3, 0dB (max. + 10dB) transformer-balanced
 - test tone-frequency line 22 KHz and 1kHz (faded, not permanent)
 - test tone-frequency fire mic. 1 KHz

 - 100V-switching relay 8 max. Voltage. 160V AC
max. switching current.4A AC
(Pmax. 800W/100V)
 - other relay contacts max. 120V AC max. 2A AC
 - display LCD with 2-lines of 20 character
 - audio-memory SD-Card (up to 16GB), *.mp3

 - line voltage 230VAC, 50 60 Hz
 - fuse; 5x20mm 3,15A slow blow
 - emergency DC-power 24V max. 600mA
 - temperature range -5°C < T < 55°C
 - power consumption max. 25 VA
 - Housing 19", 2 HE (depth: 300mm, without connectors)
Steel-sheet, black

 - weight 5 kg
- Security information: Do not expose the amplifier to rain or the environment where it may be splashed by water or other liquids, for doing so, it may cause fire or electric shock. The power plug is for disconnecting the unit from main power, keep the plug reachable. Only use on main plug with protection earth pin present.

EVA FirePanel

- microphon dynamic (500Ohm)
 - microphone - sensitivity 2,2mV/Pa (1KHz)
 - frequency response 150Hz – 12 KHz
 - Alarmzones 4
 - Fire-Mic zones 4
 - Indicators LED
 - Relay controlling by FDS 24V 2KOhm
 - Relay contact- ERROR max. 120V AC max. 2A AC
 - Power supply DC 18V – 30V DC
 - Power consumption max. approx. 60mA
 - Cabeling 4*2*0,8 mm (max. 500m)
 - Temperatur range -5°C > T > 55°C
 - housing wall mount (305x235x140mm)
 - sheet steel, red
 - Weight 4,5 Kg
-
- Security information: Do not expose the amplifier to rain or the environment where it may be splashed by water or other liquids, for doing so, it may cause fire or electric shock. The power plug is for disconnecting the unit from main power, keep the plug reachable. Only use on main plug with protection earth pin present.

Jumper1: when jumper1 is removed, the start of an external alarm request will be delayed ten seconds; so the external request has to be present for a minimum of ten seconds.

Jumper2: when jumper1 is removed, internal sounder works during an alarm or a microphone call.



GRÄF & MEYER GmbH

Ringstraße 1
D 66459 Kirkel-Limbach / Saar
Tel.: 06841 / 93 4 93 – 0
Fax.: 06841 / 93 4 93 – 10
Info@gplusm.de
www.gplusm.de